

Reference Manual

Segway Personal Transporter (PT) i2, x2

 **WARNING**

RISK OF DEATH OR SERIOUS INJURY.

Whenever you ride the Segway PT, you risk death or serious injury from loss of control, collisions, and falls. To ride safely, you must read and follow all instructions and warnings in the User Materials.

Reference Manual
Segway® PT
i2, x2

Copyright, Trademark and Contact Information

Copyright © 2006 Segway[®] Inc. All rights reserved.

Trademarks

Segway Inc. (“Segway”) owns a number of trademarks including but not limited to, Segway and the Segway “flyguy” logo that have been registered in the United States and in other countries.

Those trademarks followed by [®] are registered trademarks of Segway Inc. that have been registered in the United States and in other Countries. All other marks are trademarks or common law marks of Segway Inc. Failure of a mark to appear in this guide does not mean that Segway Inc. does not use the mark, nor does it mean that the product is not actively marketed or is not significant within its relevant market. Segway reserves all rights in its trademarks. All other trademarks are the property of their respective companies.

Contact Information

For support, please contact the company from which you bought the products. For a listing of Authorized Segway Dealers and Distributors, refer to the Segway website at: <http://www.segway.com>.

Segway Customer Care: 866.4SEGWAY (866.473.4929)

Fax: 603.222.6001

E-mail: technicalsupport@segway.com

Website: <http://www.segway.com>

Part Number: 20602-00001aa

Contents

Preface

About This Manual	ix
The Risk of Injury	x
Before You Begin	xi
Related User Materials	xi
Conventions	xii

1 Introduction

Recording Serial Numbers	1
Segway PT Serial Number	2
InfoKey Controller Serial Number	3
Segway PT Model Descriptions	4
Segway PT Specifications	5
Operating Limits	8
Weight Limits for Riders and Cargo	8
Dynamic Weight Limits	8
Minimum Weight Limit	9
Handlebar Cargo	9
Structural Weight Limits	10
Maximizing Range	11

2 Getting to Know Your Segway PT

How the Segway PT Works	13
Segway PT Components and Subsystems	16
InfoKey Controller	19
InfoKey Controller Buttons	19
InfoKey Controller Display Area	20
Power/Standby Button Functions	24
Beginner Button Functions	25
Information Display Button Functions	26
Security Button Functions	30
Button Combination Functions	31
LeanSteer Frame/Handlebar Assembly	34
Tire/Wheel Assembly and Fenders	34
Mats	35
Powerbase	35
Console	35

Understanding the Rider Detect Sensors	41
Controller Boards	43
Motors	44
Balance Sensor Assembly	45
Batteries	46
3 Understanding the Safety Alerts	
Speed Limiter	48
Stick Shake Warning	51
Rider On	52
Rider Off	54
Safety Shutdown	55
Empty Battery Condition	59
4 Using the Batteries	
Battery Safety	61
Specifications for the Batteries	63
Charging Your Batteries	64
Unplugging the Segway PT	68
Battery Charge Indicator Lights	69
Charging Failures	70
Regenerative Braking	70
Reading the Battery Charge Level Display	71
Surface Charge (Partial Charge)	72
Recalibrating the Display	72
How Temperature Affects Performance	74
Riding in Hot or Cold Temperatures	74
Charging in Hot or Cold Temperatures	76
Replacing Batteries	77
Replacing Batteries in Pairs	77
Transporting and Shipping Batteries	78
Shipping Li-ion Batteries	79
5 Operating and Maintaining Your Segway PT	
Lifting Your Segway PT	82
Maintaining Tires and Wheels	84
Checking the Tire/Wheel Assembly	84
Checking Tire Inflation Pressure	84
Cleaning Your Segway PT	86
Avoid Submerging Your Segway PT	87
Storing Your Segway PT	88

6 Servicing Your Segway PT

General Information	89
Parts Diagram	90
Replacing Parts	91
Torque Specifications	91
Accessories	91
Service Procedures	92
Removing the LeanSteer Frame	93
Attaching the LeanSteer Frame	96
Removing the Handlebar	98
Attaching the Handlebar	99
Removing the Batteries	100
Reattaching the Batteries	102
Checking Tire Inflation Pressure	104
Removing the Tire/Wheel Assembly	106
Installing the Tire/Wheel Assembly	107
Removing/Installing the Fenders	108
Removing/Installing the Mats	109
Replacing the InfoKey Controller Battery	110
Removing/Replacing the Console Trim	112
Installing/Removing the InfoKey Controller Dock	113
Installing/Removing the Dock Adapter	115
Docking/Undocking the InfoKey Controller	116

7 Troubleshooting the Segway PT

Troubleshooting Procedures	119
Segway PT Will Not Power On	122
Segway PT Will Not Enter Balance Mode	123
The LeanSteer Frame Slips or is Off-Center	124
Tire/Wheel Assembly is Loose and Wobbles	125
Segway PT Pulls To One Side When Riding	126
Tire is Flat or Will Not Hold Air	127
Safety Shutdown At Building Entrance	127
The Segway PT Will Not Power Down	128
Diagnosing Errors with InfoKey Controller Icons	130
Startup Error Conditions	130
Balance Mode Error Conditions	132
Reduced Performance Levels	133
Critical Faults While Riding	134
Pitch or Roll Angle Exceeded	135
System Faults	136

A Contact and Legal Information

Report All Incidents	137
How to Reach Us.....	137
California Warning	137
Obey All Laws and Regulations.....	138
Limited Warranty	138
Radio Frequency Interference	138
Canadian ICES-003	139
European Directives.....	139
Other Standards.....	140
Patent Information	141
Index	143

Preface

Congratulations on the purchase of your new Segway® Personal Transporter (PT)!

The Segway PT is the standard term used to refer to the self-balancing Segway products described in this manual. Each Segway PT model (i2 or x2) is different, but the fundamentals found in this manual apply to both models.

About This Manual

To learn to ride your Segway PT, you must read and follow all instructions and warnings in the Getting Started Manual and watch the Safety Video.

It is important that you follow all safety warnings and cautions that appear throughout your Segway PT manuals and that you use good judgment when you ride your Segway PT.

If you have questions, or do not have the Getting Started Manual or Safety Video, contact an Authorized Segway Dealer or Distributor, or Segway Inc. (Segway) before you attempt to use your Segway PT.

For a list of Authorized Segway Dealers and Distributors, refer to www.segway.com.

The Risk of Injury

The Segway PT is a self-balancing, personal transporter that uses patented balancing technology. Balancing technology cannot prevent injury if you do not ride the Segway PT safely.



WARNING!

RISK OF DEATH OR SERIOUS INJURY

Whenever you ride the Segway PT, you risk death or serious injury from loss of control, collisions, and falls. To reduce risk of injury, you must read and follow all instructions and warnings in the User Materials.

Before You Begin

Before you begin, it may be necessary to assemble your Segway PT. The Batteries should be charged for 12 hours. To assemble the Segway PT and charge the Batteries for the first time, refer to the Segway PT Getting Started Manual.

If you do not have the Segway PT Getting Started Manual, contact an Authorized Segway Dealer or Distributor, Segway Customer Care, or download it from www.segway.com.





Related User Materials

- **Getting Started Manual** - The Segway PT Getting Started Manual provides information to help you assemble and learn to ride your new Segway PT. To reduce risk of injury, you must read and follow all instructions and warnings in the Getting Started Manual.
- DVD that contains:
 - **PDF files of each manual.** Segway provides an electronic copy of this Reference Manual and the Getting Started Manual on DVD for your convenience. The content of the electronic copy is the same as the printed books. You will need Adobe Reader[®] to access the PDF files.
 - **Safety Video.** The Safety Video is included on the same DVD as the manuals. It provides important information on how to use your Segway PT. To reduce the risk of injury, you must watch and follow all instructions and warnings in the Safety Video before you ride.

DVDs are shipped in NTSC format for viewing in North America (USA, Canada, Mexico) and Japan and in PAL format for viewing in most parts of Europe, Asia, Australia and New Zealand.

Conventions

The following conventions are used throughout this guide:

 WARNING!	Warns you about actions that may result in personal injury.
 CAUTION	Cautions you about actions that may result in operational issues or physical damage to the Segway PT.
 NOTE:	Identifies important points, helpful hints, special circumstances, or alternative methods.
	Indicates a reference to another section of this document or to the Getting Started Manual.

Chapter 1:

Introduction

This chapter introduces the Segway PT. It includes:

- Instructions on how to locate and record the serial number of your Segway PT and the wireless InfoKey™ Controller.
- Segway PT model descriptions.
- Detailed specifications and operating limits of the Segway PT.

Recording Serial Numbers

Record the unique serial numbers for both the Segway PT and the InfoKey Controller. Store this information in a secure location, separate from your Segway PT in case you need to order a replacement InfoKey Controller.

The Segway PT and InfoKey Controller serial numbers are unique to your machine and InfoKey Controller. These numbers can provide helpful information in the future for asset and warranty tracking, InfoKey Controller replacement, insurance claims, and in case of loss or theft. Store the serial numbers in a secure location, separate from your Segway PT.

Segway PT Serial Number

To record the Segway PT Serial Number:

1. Stand behind the Segway PT and lift the back edge of the right Mat to expose the bar code label.
2. Locate the serial number on the left side of the label. The serial number is a 12-digit number beginning with “0” (see **Figure 1**).

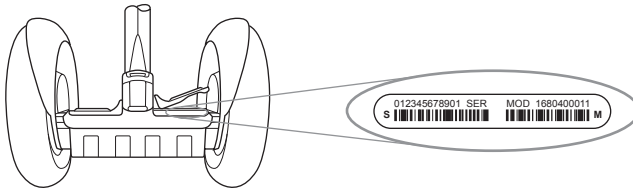

Figure 1. Location of Segway PT Serial Number

3. Record the Segway PT serial number and keep it in a safe place.
 4. Resecure the Mat in place after you record the serial number.
- ▶ ▶ For more information, see “**Removing/Installing the Mats**” on page 109

InfoKey Controller Serial Number

To record the InfoKey Controller serial number:

1. Locate the serial number beginning with S/N, on the back of your InfoKey Controller (located under the trim ring) (see **Figure 2**).

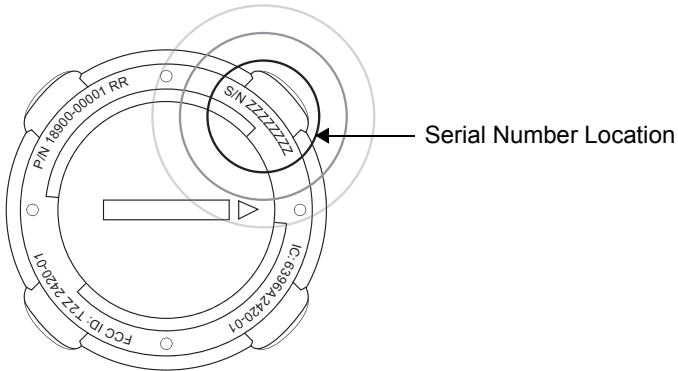

Figure 2. Location of InfoKey Controller Serial Number

2. Record the InfoKey Controller serial number.

Segway PT Model Descriptions

Table 1 lists the Segway PT models described in this manual.

Table 1. Segway PT Model Descriptions

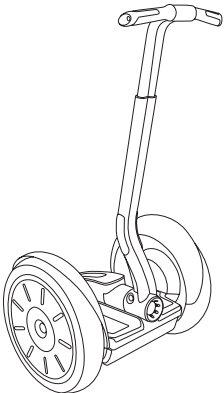
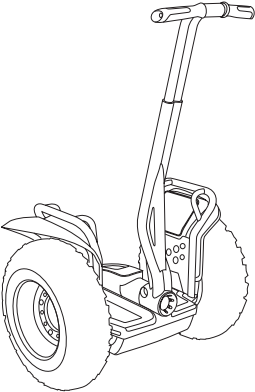
Model Name	Description
<p data-bbox="157 326 181 350">i2</p> 	<p data-bbox="546 326 857 407">The i2 model is optimized for indoor/outdoor use in a wide variety of environments.</p>
<p data-bbox="157 824 189 849">x2</p> 	<p data-bbox="546 824 900 1141">The x2 model is optimized for outdoor use. The x2 has larger Wheels and wider Tires with knobby treads, and is intended for use on more varied and rugged terrain than other models. The x2's wider stance and low-pressure Tires provide increased stability and traction on rough terrain. The x2 is not intended for use on sidewalks.</p>

▶ ▶ For more information about how the Segway PT works see **Chapter 2, "Getting to Know Your Segway PT."**

Segway PT Specifications

Table 2 shows the specifications for the Segway PT models described in this manual.

Table 2. Segway Specifications

Model Specification	i2	x2
Rider Weight and Cargo Limits*		
Max. Payload (Rider Plus all Cargo)	260 lbs 117 kg	260 lbs 117 kg
Min. Rider Weight	100lbs 45 kg	100 lbs 45 kg
Max. Handlebar Cargo Weight	10 lbs 4.5 kg	10 lbs 4.5 kg
Performance		
Max. Speed:	12.5 mph 20 km/h)	12.5 mph 20 km/h
Energy (Rechargeable Batteries)	Lithium Ion (Li-ion)	Lithium Ion (Li-ion)
Range on a Full Charge**	16 to 24 mi 26 to 39 km	9 to 12 mi 14 to 19 km
Turning Radius	Zero. The Wheels can rotate in opposite directions, enabling the Segway PT to turn in place.	
Tire Inflation Pressure	15 psi 1.03 bar	4 psi .275 bar
Power Requirements (Worldwide)	100 to 240 V~; 50 or 60 Hz	100 to 240 V~; 50 or 60 Hz

Table 2. Segway Specifications

Model Specification	i2	x2
Dimensions		
Machine Weight Without Batteries	82 lbs 37 kg	97 lbs 44 kg
Battery Weight	See Table 10 on page 63.	
Ground Clearance (Unloaded)	3.4 in 8.5 cm	4.4 in 11.2 cm
Machine Length and Width	25.5 x 25 in 65 x 63 cm	26.5 x 33 in 67 x 84 cm
Handlebar Height from Mat	38 - 43 in 97 -109 cm	38 - 43 in 97-109 cm
Handlebar Height from Ground (Unloaded)	46 - 51 in 117-130 cm	47 - 52 in 119 - 132 cm
Powerbase Height (Unloaded)	8 in 20 cm	9 in 22.9 cm
Tire Diameter	19 in 48.3 cm	21 in 53.3 cm
Tire Type	Standard	All-terrain
InfoKey Controller		
Battery	CR2430 replacement batteries are available at Electronics stores. A spare InfoKey Controller battery ships with your new Segway PT, stored beneath the Console Trim.	



NOTE:

* See **“Weight Limits for Riders and Cargo”** on **page 8** for more information on weight limits.

** See **“Maximizing Range”** on **page 11** for information on maximizing the distance you can travel on your Segway PT, and factors that can increase or reduce your range.

Operating Limits

It is important that you familiarize yourself with the operating limits of the Segway PT. These limits are set to maximize rider safety while reducing the risk of damage to the Segway PT. The Segway PT will perform better when you observe these limits.

Weight Limits for Riders and Cargo

Segway sets weight limits for two reasons:

- Rider safety.
- To reduce the risk of damage to the Segway PT.

Dynamic Weight Limits

To keep the Segway PT and rider upright, the Segway PT must always have enough power to be able to turn its Wheels forward and backward.



WARNING!

Exceeding the weight limits, especially when combined with other variables that require more power, will increase your risk of falling or damaging the Segway PT.

Variables that require more power include:

- Higher payloads (weight of rider and all cargo).
- Steeper slopes.
- Bumpier surface conditions.
- Higher speeds.
- Abrupt maneuvers.

The Segway PT monitors the amount of power being used and will activate safety alerts when it senses excessive power demands. It is important that you learn to anticipate and recognize when the Segway PT is reaching the limits of performance.

- ▶ ▶ Learn to recognize and respond to Safety Alerts; review “**Speed Limiter**” on page 48, “**Stick Shake Warning**” on page 51, and “**Safety Shutdown**” on page 55.

Minimum Weight Limit

The rider’s weight must not be less than 100 lbs. (45 kg). If the rider is below the minimum rider weight limit, he/she may not be able to ride safely because he/she cannot shift his/her weight far enough back (behind the centerline of the Wheels) to safely slow down and stop. This is especially true when riding downhill. Also, riders below the minimum weight limit might fail to properly interact with the Segway PT’s balancing system.

Handlebar Cargo

The total weight of any Handlebar payload plus any other attachments hanging from the Handlebar must not exceed 10 lbs (4.5 kg).



WARNING!

Exceeding this Handlebar Cargo limit interferes with the Segway PT’s balancing ability and could cause the Segway PT to accelerate forward, risking injury and damage.

Structural Weight Limits

Exceeding the maximum weight limit increases the risk of damage to the Segway PT. Heavier payloads place greater stress on the Segway PT. Several factors affect the loads transmitted to the Segway PT:

- Skill level of the rider.
- Payload (weight of the rider and all cargo).
- Surface condition (obstacle height, etc.).



Exceeding the rider or cargo weight limits, especially when riding on uneven terrain, could damage the Segway PT.

Maximizing Range

Maximum range distances are provided in **Table 2 on page 5**. The range of your Segway PT is affected by many variables, including:

- **Terrain:** Riding on smooth, flat terrain improves range, and riding on hilly terrain and unpaved surfaces reduces range.
- **Speed and Riding Style:** Riding at a consistent, moderate speed will increase range while frequent starting, stopping, acceleration, and deceleration reduces range.
- **Tire Inflation Pressure:** Riding with tire pressures below the specified limit reduces range.
- **Rider Weight and Cargo:** Lighter riders with less cargo experience better range than heavier riders with more cargo.
- **Temperature:** Storing, charging, and riding in temperatures close to the median of the recommended temperature range improves range. Riding in colder temperatures reduces range significantly.
- **Battery Condition:** Properly charged and maintained Batteries provide greater range. Old, cold, heavily used, or poorly maintained Batteries provide less range.
- **Wind:** Riding with a tailwind increases range. Riding against a headwind reduces range.

Chapter 2:

Getting to Know Your Segway PT

This chapter describes how the Segway PT works. It includes:

- A description of the InfoKey Controller and its buttons and icons.
- Information about Segway PT components.

How the Segway PT Works

The Segway PT works like the human body. When walking, if you lean forward, you take a step forward to keep your balance. If you lean back, you step back. On a Segway PT when you lean forward or back the machine powers the Wheels in the direction that you lean.

The Segway PT uses technology called dynamic stabilization to maintain its balance and move forward or backward.

When you lean, your center of gravity moves beyond the contact patch (the place where the tire contacts the ground) causing the Segway PT to tilt. The Segway PT's systems sense this change, powering the Wheels to keep them underneath you. See **Figure 3**.

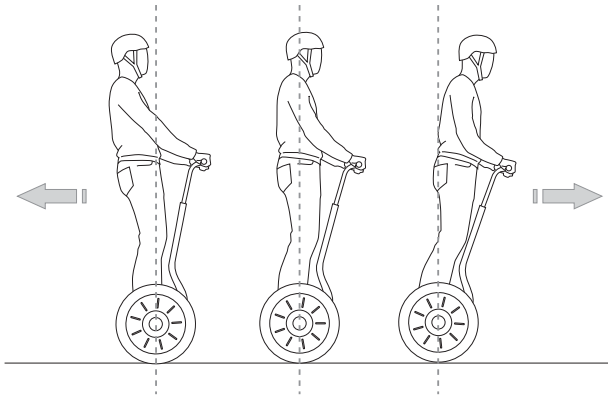

Figure 3. How the Segway PT Works - Leaning Forward and Back

When you pivot the LeanSteer Frame left, the Segway PT turns left. When you pivot the LeanSteer Frame right, the Segway PT turns right. To turn the Segway PT, point the LeanSteer Frame in the direction you want to go, keeping the Handlebar in line with your body. When the LeanSteer Frame is centered, the Segway PT travels straight ahead. See **Figure 4**.

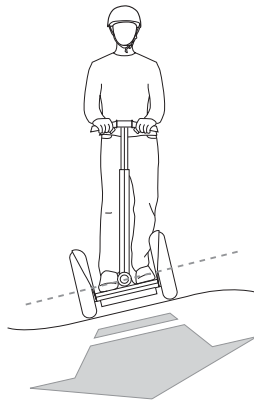

Figure 4. How Segway PT Works - Turning

The Segway PT's dynamic stabilization technology balances forward and backward but not side-to-side. If you tip the Segway PT onto one Wheel, it will not dynamically bring itself underneath you and it could fall over. You are responsible for maintaining side-to-side stability while riding the Segway PT. To do this, keep your body aligned with the LeanSteer Frame. Lean into turns and lean uphill when riding across a slope to maintain side-to-side balance.



NOTE:

When riding across a slope with one Wheel higher than the other, keep the LeanSteer Frame vertical to keep from turning.

Segway PT Components and Subsystems

The Segway PT includes the following components and subsystems (see **Figure 5**):

- InfoKey™ Controller
- InfoKey Controller Dock
- Handlebar
- LeanSteer Frame
- Tire/Wheel Assembly and Fenders
- Console with Charge and Balance Indicator Lights
- Console Trim
- Mats
- Powerbase
- Batteries

The Segway PT has been designed with concern for the safety of the rider and those who may be nearby. Redundant subsystems maintain controlled operation of the Segway PT in the unlikely event of a component failure. If one component in a subsystem fails, the other component continues to operate, allowing you to come to a complete and safe stop before stepping off. The Segway PT has five redundant subsystems: Controller Boards, Motors, Batteries, the Balance Sensor Assembly, and LeanSteer Sensors.



WARNING!

All Segway PT parts must be approved by Segway, and properly installed. Never attempt to stand on a Segway PT without the LeanSteer Frame attached and secured. Using your Segway PT without all parts properly installed could damage your Segway PT and result in serious injury from loss of control, collisions, and falls.



WARNING!

Do not modify the Segway PT. Modifications to the Segway PT without the prior written approval of Segway could interfere with the operation of the Segway PT, could result in serious injury and/or damage, and could void the Segway PT Limited Warranty.

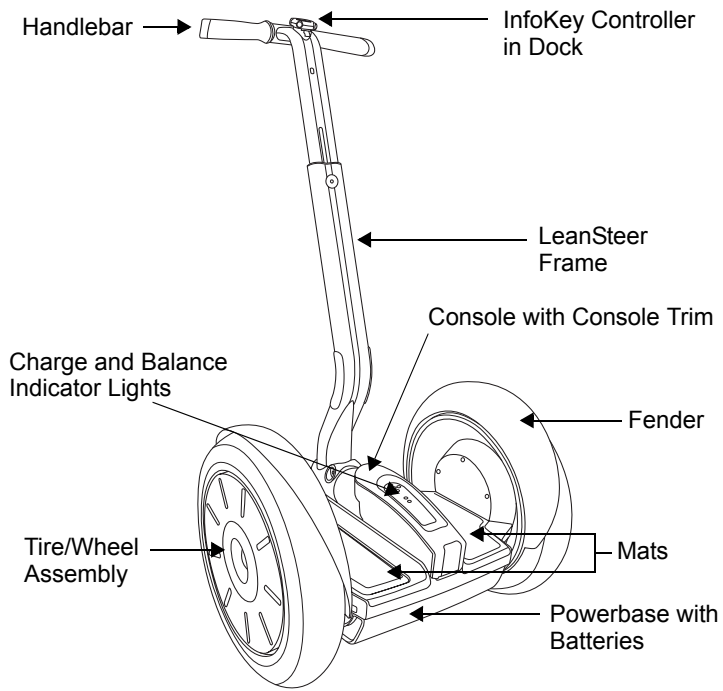

Figure 5. Segway Components

InfoKey Controller

You use the InfoKey Controller to operate and monitor your Segway PT. The InfoKey Controller has four buttons around the outer edge and a display in the center. The InfoKey Controller must be within 15-ft. (5m) in order to communicate with your Segway PT.

InfoKey Controller Buttons

The buttons allow you to select Segway PT functions and scroll through information.

Figure 6 shows the buttons on the InfoKey Controller.

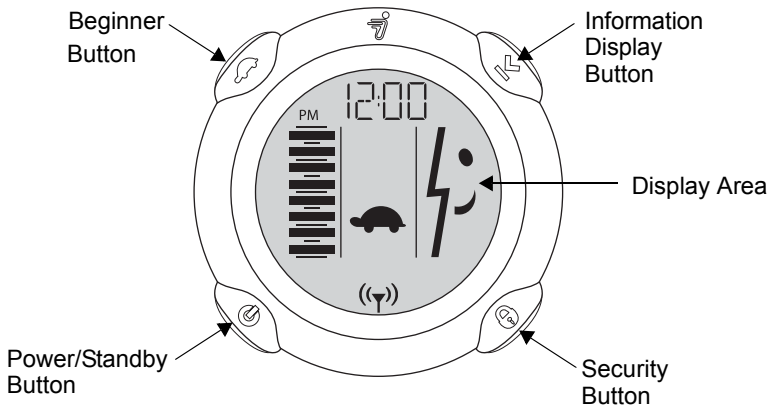

Figure 6. InfoKey Controller Buttons

InfoKey Controller Display Area

The Display Area provides status information such as messages and warnings.

Figure 7 shows icons and data that display on the InfoKey Controller.

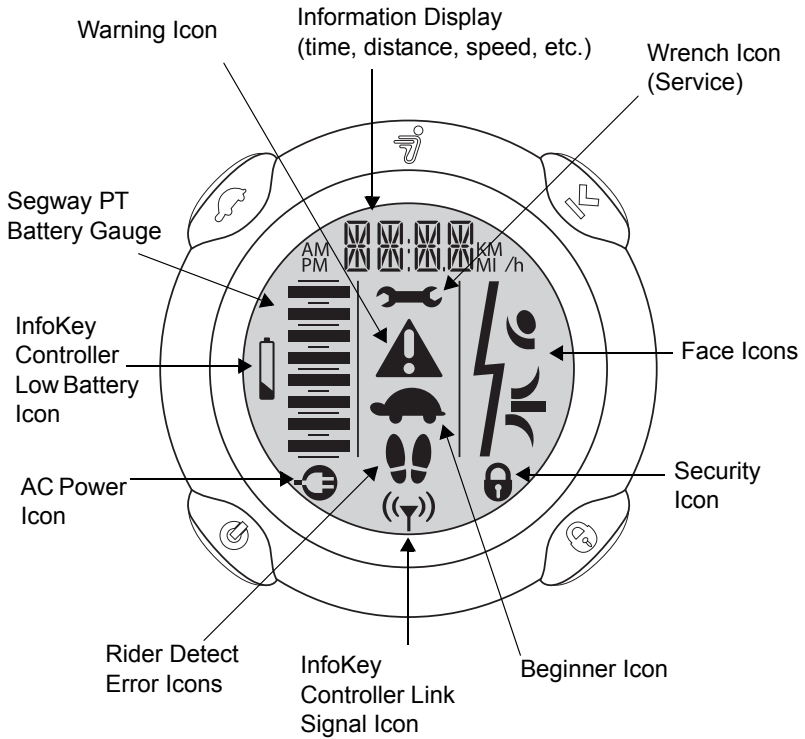

Figure 7. InfoKey Controller Display

Table 3 describes each of the buttons and icons.

Table 3. InfoKey Controller Buttons and Icons





Control	Description
Buttons	
Power/Standby button 	Allows you to power the Segway PT on and off and switch from Balance Mode to Standby Mode.
Beginner button 	Allows you to toggle the Beginner Setting on and off and illuminate the Backlight.
Information Display button 	Allows you to scroll through information including time, date, speed, average speed, trip distance, and odometer. Allows you to set time, speed/distance format, date and reset the average speed and trip distance.
Security button 	Allows you to activate the security function (alarm).

Table 3. InfoKey Controller Buttons and Icons











Control	Description
Icons/Controls on Display	
Information Display 	Displays time, date, speed, average speed, trip distance and odometer.
Wrench icon 	Indicates a system fault on the Segway PT that requires service.
Face icons 	A series of face icons display to indicate status. For example, you may see a happy face, sad face, or neutral face.
Security icon 	Indicates the security function is activated.
Beginner icon 	A turtle indicates that the Beginner Setting is enabled (top speed and turning sensitivity are set at lower rates). When the Beginner icon is not displayed, the Beginner Setting has been disabled.
InfoKey Controller Link Signal icon 	Indicates the InfoKey Controller has detected the Segway PT. The InfoKey Controller must be within 15 ft. (5m) in order to communicate with your Segway PT.

Table 3. InfoKey Controller Buttons and Icons

Control	Description
<p>Rider Detect Error icons</p> 	<p>If any two of the four Rider Detect Sensors (two located beneath each Mat) are not depressed while you are riding, the Rider Detect Error icons will be displayed. The Rider Detect Error icons display in Standby Mode if you attempt to step onto a Segway PT that is not ready to ride. Rider Detect Error icons display at startup if there is any weight on the Mats.</p>
<p>AC Power icon</p> 	<p>Indicates the Segway PT is plugged in to AC power.</p>
<p>InfoKey Controller Low Battery icon</p> 	<p>Indicates the InfoKey Controller battery must be replaced. Dispose of the battery properly in accordance with regulations governing disposal of toxic materials. CR2430 replacement batteries are available at electronics stores. A spare InfoKey Controller battery ships with your new Segway PT, stored beneath the Console Trim.</p>
<p>Segway PT Battery Gauge</p> 	<p>Indicates the amount of power remaining in the Segway PT Batteries.</p>
<p>Warning icon</p> 	<p>Indicates a warning condition caused by factors such as aggressive riding, system operating outside of temperature range, rider lifting foot off of Mat, etc.</p>

Power/Standby Button Functions

The following functions can be performed using the Power/Standby button.

Powering On and Off

To power on the Segway PT:

1. Stand no more than 15 ft. (5m) from your Segway PT.
2. To power on, tap the Power/Standby button.
3. To power off, press the Power/Standby button for 2 seconds.

The Segway PT will only power off when no Rider Detect Sensors are depressed (when there is no weight on the Mats).

Switching to Standby Mode from Balance Mode

1. Ensure the Segway PT is powered on and in Balance Mode.
2. To switch to Standby Mode, tap the Power/Standby button.
3. Confirm that there is no face in the Display and that no Balance Indicator Lights are flashing.

If all four Balance Indicator lights are green and flashing, the Segway PT is still in Balance Mode.

- ▶ ▶ See “**Understanding Balance Mode**” in the Getting Started Manual.

The Segway PT will only accept this command when no Rider Detect Sensors are depressed (when there is no weight on the Mats).

Beginner Button Functions

The following functions can be performed using the Beginner button.

Enabling and Disabling the Beginner Setting

1. To disable the Beginner Setting, confirm that the Beginner icon (turtle) is displayed, then tap the Beginner button. The Beginner icon will no longer show in the Display.
2. To enable the Beginner Setting, confirm that the Beginner icon is not displayed, then tap the Beginner button. The Beginner icon will show in the Display.

The Segway PT will only accept these commands when no Rider Detect Sensors are depressed (when there is no weight on the Mats).

- ▶ ▶ See “**Configuring and Locking the Beginner Setting**” on **page 31** for more information. This action requires a combination of buttons.

Illuminating the Backlight

1. Press and hold the Beginner button to illuminate the Backlight.
2. Release the Beginner button to turn off the Backlight.

Information Display Button Functions

The following functions can be performed using the Information Display Button.

Scrolling Through Information

Tap the Information Display button to scroll through the following information:

- Time
- Date
- Current speed
The speed/distance format flashes.
- Average speed
The speed/distance format does not flash; all trips are averaged until you reset the average speed function.
- Trip distance
The speed/distance format flashes, and shows distance traveled with no leading "0"s.
- Odometer
The speed/distance format does not flash, and shows total distance traveled on the Segway PT.



NOTE:

When you replace or reseal the InfoKey Battery, all information will revert to the default setting. Trip distance and average speed will reset to "0." The odometer will not reset.

Setting and Resetting Information

The following procedures are covered in this section:

- Setting time format, hour and minute
- Setting speed/distance format, date format, year, month, and day
- Resetting average speed
- Resetting trip distance

Setting Time Format, Hour, and Minute

1. **Set Time Format (12- or 24-hour Clock)**

Tap the Information Display button until the time displays.

Press and hold the Information Display button until the time format segment flashes either “12” or “24.”

Select the 12- or 24-hour format by tapping the Security button until the desired format is displayed.

Release the Information Display button.

Tap the Information Display button to confirm and advance to the hour setting.

2. **Set Hour**

Select the hour by tapping the Security button until the desired hour is displayed. Press and hold the Security button to fast-advance hours.

Tap the Information Display button to confirm and advance to the minute setting.

3. **Set Minute**

Select the minute by tapping the Security button until the desired minute is displayed. Press and hold the Security button to fast-advance minutes.

Tap the Information Display button to confirm the time setting. The time is now set.

Setting Speed/Distance Format, Date Format, Year, Month, and Day

1. Set Speed/Distance Format (MI or KM)

Tap the Information Display button until you see the month/day or day/month alternating with the year.

Press and hold the Information Display button until the MI/H or KM/H shows in the display.

Release the Information Display button.

Select the MI/H or KM/H format by tapping the Security button until the desired format is displayed.

Tap the Information Display button to confirm and advance to the date format setting.

2. Set Date Format (MO.DA or DA.MO)

Select the MO.DA (Month.Day) or DA.MO (Day.Month) format by tapping the Security button until the desired format is displayed.

Tap the Information Display button to confirm and advance to the year setting.

3. Set Year

Select the year by tapping the Security button until the desired year is displayed. Press and hold the Security button to fast-advance years.

Tap the Information Display button to confirm and advance to the month setting.

4. Set Month

Select the month by tapping the Security button until the desired month is displayed. Press and hold the Security button to fast-advance months.

Tap the Information Display button to confirm and advance to the day setting.

5. **Set Day**

Select the day by tapping the Security button until the desired day is displayed. Press and hold the Security button to fast-advance days.

6. Tap the Information Display button to confirm speed/distance format, date format, year, month, and day. These are now set.

Resetting Average Speed

Tap the Information Display button until you see the average speed (“MI/h” or “KM/h” does not flash).

Press and hold the Information Display button until average speed resets to “0.0.”

Resetting Trip Distance

Tap the Information Display button until you see your trip distance (“MI” or “KM” flashes).

Press and hold the Information Display button until the trip odometer resets to “0.0.”

Security Button Functions

The following functions can be performed using the Security Button.

Enabling and Disabling the Security Function

1. To enable the Security Function, tap the Security button. The Security icon (lock) will show in the Display.
2. To disable the Security Function, tap the Security button. The Security icon (lock) will no longer show in the Display.

The Segway PT will only accept these commands when no Rider Detect Sensors are depressed (when there is no weight on the Mats).

The Security Function includes an alarm and a mechanism that makes it difficult to move your Segway PT and discourages tampering. The best way to deter theft of your Segway PT is to keep it in a secure indoor location with the InfoKey Controller stored separately. If you must leave your Segway PT unattended in a location that is not secure, enable the Security Function and remain within audible range so you can respond, should the alarm sound.

Button Combination Functions

The following functions require you to simultaneously push a combination of InfoKey Controller buttons.

Configuring and Locking the Beginner Setting

For your first ride, the Segway PT is set to operate exclusively with the Beginner Setting enabled. If the Beginner icon (turtle) does not display, do NOT ride the Segway PT until you enable the Beginner Setting.

The Segway PT ships from the factory with the Beginner Setting locked, to encourage new riders to learn using the Beginner Setting. To unlock the Beginner Setting:

1. Power on the Segway PT.
2. Press and hold the Beginner Button and the Information Display Button simultaneously for more than 10 seconds. The Information Display button will flash.
3. Confirm that the Beginner icon (turtle) toggles when the Beginner button is tapped.

Once the Beginner Setting is unlocked, you can toggle the Beginner Setting on or off by tapping the Beginner button.

To lock the Beginner Setting:

1. Repeat Steps 1 and 2 above.
2. Confirm that the Beginner icon (turtle) is showing on the InfoKey Display.
3. Test the lock by tapping the Beginner button and confirming that the Beginner icon remains showing in the InfoKey Display.

Activating the Training Safety Shutdown

Before you demonstrate a Safety Shutdown for training purposes, you must read about “**Safety Shutdown**” in the Getting Started Manual, and watch the Safety Video. The purpose of demonstrating Safety Shutdown for training purposes is to introduce the rider to the experience while in a predictable, controlled environment with a spotter. Read all the following steps prior to activating the Training Safety Shutdown.

1. Make sure the Segway PT is in Balance Mode.
2. The rider should stand on the Mats with the Segway PT remaining stationary.
3. The spotter should firmly hold the Segway PT, ready to keep it steady and stationary when the Safety Shutdown begins.
4. A third person should hold the InfoKey Controller, and confirm that both the rider and the spotter are ready.

- The third person may then press and hold both the Information Display button and the Power/Standby button simultaneously until the Safety Shutdown initiates. **Figure 8** shows the InfoKey Controller display during a training Safety Shutdown.

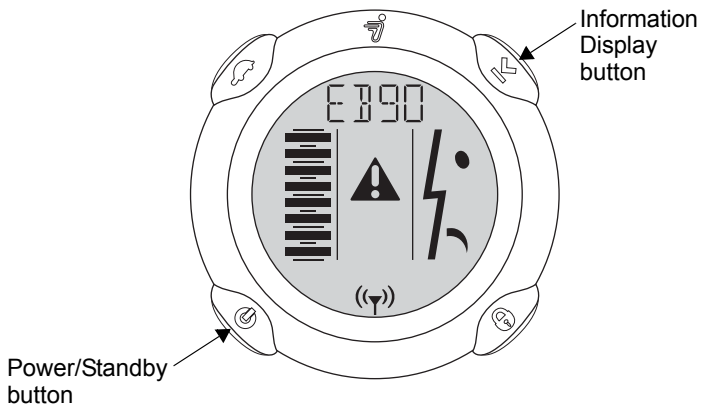

Figure 8. InfoKey Controller Display During a Training Safety Shutdown

- The spotter must continue holding the Segway PT so it does not move.
- The rider must step off the Segway PT before 10 seconds elapse. The rider has approximately 10 seconds from the start of a Safety Shutdown to come to a controlled stop and step off. After 10 seconds, the Segway PT will immediately shut down when the Wheels reach zero speed.

LeanSteer Frame/Handlebar Assembly

Ensure the following:

- The Handlebar is attached to the LeanSteer Frame.
- The LeanSteer Frame is attached to the Powerbase.
- The Handlebar is adjusted to the appropriate height.
 - ▶ ▶ See “**Setting Up Your Segway PT**” in the Getting Started Manual.

The LeanSteer Frame pivots at the base to control left/right direction of the Segway PT.

If you lean to the left while holding the Handlebar, the LeanSteer Frame pivots and the Segway PT turns left. If you lean to the right while holding the handlebar, the LeanSteer Frame pivots and the Segway PT turns right. Always lean left or right in coordination with the LeanSteer Frame.

Tire/Wheel Assembly and Fenders

Ensure that Tires are inflated to the proper tire inflation pressure as specified in “**Segway PT Specifications**” on page 5.

Tires and Wheels are shipped as an assembly. Do not remove the Tire from the Wheel.

The Fenders on the Segway PT are designed to protect the rider from debris and to safeguard the rider while leaning into turns.

Mats

Your Segway PT comes with two Mats installed to the right and left of the Console. These Mats protect the Rider Detect Sensors located beneath them, as well as provide a comfortable surface on which to stand. Mats should be secured in place prior to riding.

- ▶ ▶ For more information, see “**Removing/Installing the Mats**” on page 109.

Powerbase

The Powerbase consists of the following parts:

- Console
- Rider Detect Sensors
- Controller Boards
- Motors
- Balance Sensor Assembly

Console

The Console is located behind the LeanSteer Frame and between the two Mats. The Console is assembled with a cover that should not be removed. A replaceable trim piece snaps onto the cover.

There are two sets of Indicator lights on the Console (see **Figure 9**):

- Balance Indicator lights provide visual feedback about whether or not the Segway PT is ready for you to step on.
- Charge Indicator lights provide Battery charge status information for the Segway PT Batteries when the Segway PT is plugged into AC power.

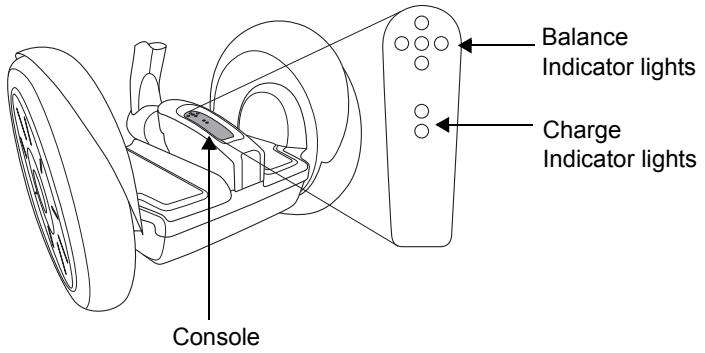

Figure 9. Console and Indicator Lights

Balance Indicator Lights

Five Balance Indicator lights are located on the Console. These lights provide visual feedback about the balancing status of the Segway PT, and help the rider determine when it is safe to step onto the Mats. See **Figure 10**.

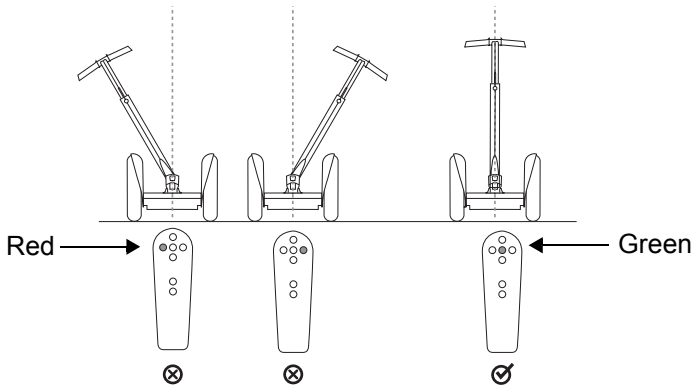

Figure 10. Balance Indicator Lights

Table 4 describes the Balance Indicator light patterns, and the corresponding balance status of the Segway PT.

Table 4. Balance Indicator Light Patterns

Segway PT Status	Light Pattern
Not Ready Do not step on.	Off: No Balance Indicator lights are illuminated. Red: One or more Balance Indicator lights are red.
Ready Step on.	Green: Only the center Balance Indicator light is green. All four other lights are not illuminated. Green: All five Balance Indicator lights are pulsing green.

Red Balance Indicator lights indicate that the Powerbase or LeanSteer Frame are tilted, and the Segway PT is not ready to be stepped on:

- **One red left or right Balance Indicator light.**
Pivot the LeanSteer Frame in the opposite direction of the red light, until the LeanSteer Frame is vertical, and the red Balance Indicator lights are replaced by one green Balance Indicator light in the center.
- **One red front or rear Balance Indicator light.**
Tilt the Powerbase in the opposite direction of the red light, until the Powerbase is level, and the red Balance Indicator lights are replaced by one green Balance Indicator light in the center.
- **Two adjacent red Balance Indicator lights.**
Move both the LeanSteer Frame and the Powerbase in the opposite direction of the lights until the red Balance Indicator lights are replaced by one green Balance Indicator light in the center.
- **Five red Balance Indicator lights.**
Pivot the LeanSteer Frame until it is vertical, level the Powerbase, make sure the Wheels are not moving, and wait until the red Balance Indicator lights are replaced by one green Balance Indicator light in the center.

Green Balance Indicator lights indicate that the Segway PT is ready to be stepped on, or that a rider is already on:

- **One green Balance Indicator light in the center.**
The Segway PT is in Standby Mode, ready for the rider to step on.
- **Five green Balance Indicator lights pulsing.**
The Segway PT is in Riderless Balance Mode, ready for the rider to step on.
- **Four green Balance Indicator lights rotating.**
The Segway PT is in Balance Mode with a rider on.

Battery Charge Indicator Lights

Two Charge Indicator lights on the Console indicate the charge status of the Batteries when the Segway PT is plugged in. The front Charge Indicator light corresponds to the front Battery and the rear Charge Indicator light corresponds to the rear Battery. (See **Figure 11**).

- When the Segway PT is plugged in and charging, each Charge Indicator light will either be flashing or solid green.
- If one or both Charge Indicator lights is red or fails to illuminate, there is a charging problem.
 - ▶ ▶ For more information, see “**Charging Failures**” on **page 70**.

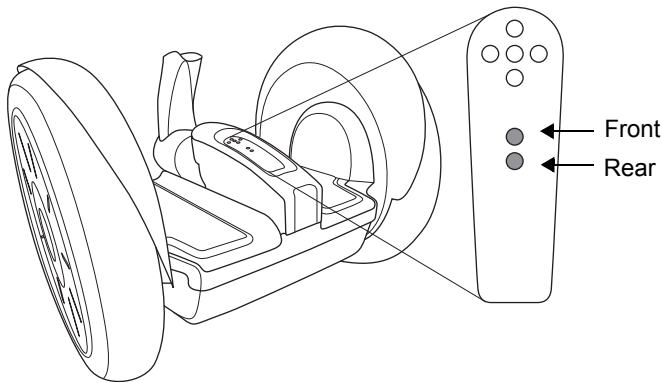

Figure 11. Battery Charge Indicator Lights

Console Trim

A trim piece fits over the Console. The Console Trim can be replaced, and allows you to personalize the trim color on your Segway PT.

A spare InfoKey Controller battery ships with your new Segway PT, stored beneath the Console Trim. CR2430 replacement batteries are available at electronics stores.

You may remove or replace the Console Trim, but do not attempt to remove the Console cover, beneath the Console Trim. The Console cover is not a user-serviceable part.

Understanding the Rider Detect Sensors

The Segway PT has four sensors located beneath the Mats. Rider Detect Sensors detect the presence or absence of a rider while the Segway PT is powered on.

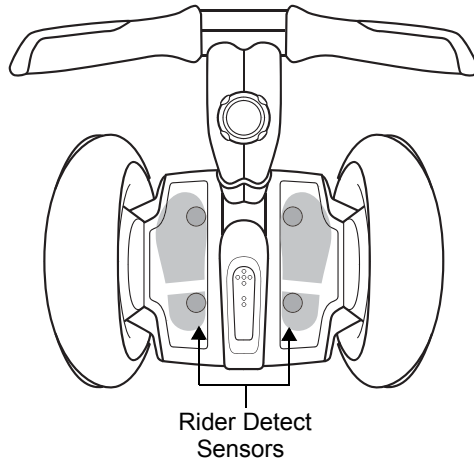

When your feet are properly positioned on the Mats, all four Rider Detect sensors depress, allowing the Segway PT to operate normally in Balance Mode.

If fewer than three Rider Detect sensors are depressed while riding, the Segway PT reduces the top speed limit regardless of whether Beginner Setting is enabled or not. Once your feet are properly positioned again, the Segway PT regains full performance.

If the Segway PT is moved too quickly while in Balance Mode and none of the Rider Detect Sensors are depressed, the Segway PT will give the Stick Shake Warning before exiting Balance Mode and transitioning to Standby Mode.



WARNING!

To prevent a riderless Segway PT from traveling on its own, never let go of it while it is in Balance Mode. It will travel some distance on its own before shutting down, risking injury to others and damage to the Segway PT.



WARNING!

Never place anything on the Mats, except your feet. Doing so could interfere with the Rider Detect Sensors and allow the Segway PT to travel on its own, risking running into a person or property, and causing injury or damage.

Controller Boards

Figure 12 shows the location of the Controller Boards.

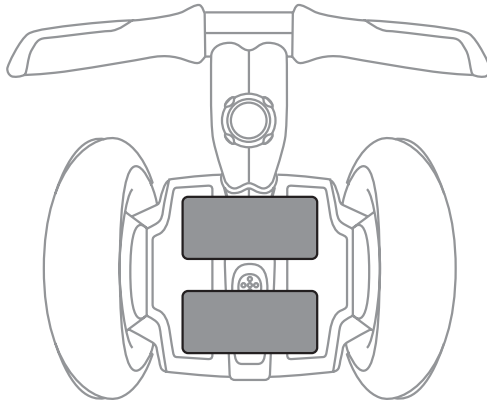

Figure 12. Location of Controller Boards

The two Controller Boards receive input from the Segway PT's Batteries, Motors, Rider Detect Sensors, LeanSteer Sensors, rate and tilt sensors. Based on this input, the Controller Boards send commands to the Motors that turn the Wheels.

If the system senses a malfunction in a critical component or a Battery that is depleted beyond its safe limit, the Segway PT will perform a Safety Shutdown.

- ▶ ▶ For more information on Safety Shutdown, see “**Safety Shutdown**” on page 55.

Motors

Figure 13 shows the location of the Motors.

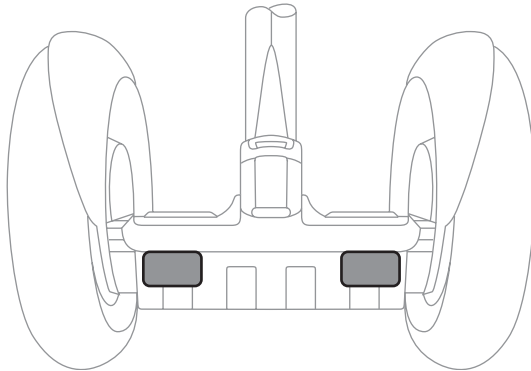

Figure 13. Location of Motors

Each Wheel is independently driven by redundant, high-speed electric Motors that are quiet and efficient. Each Motor is computer-controlled to precisely regulate the Segway PT's motion.

Each Motor is wound as two separate electrical circuits, capable of independent operation, acting as one mechanical entity. If either winding in a Motor fails, the Segway PT will perform a Safety Shutdown.

- ▶ ▶ For more information on Safety Shutdown, see “**Safety Shutdown**” on page 55.

Balance Sensor Assembly

Figure 14 shows the location of the Balance Sensor Assembly.

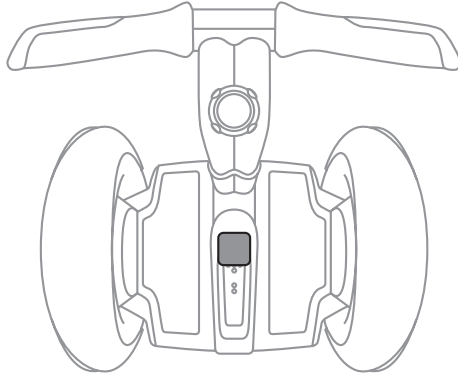

Figure 14. Location of Balance Sensor Assembly

The Balance Sensor Assembly contains five angular rate sensors (solid state gyroscopes) and two tilt sensors. The Balance Sensor Assembly sends information about the Segway PT's orientation to the Controller Boards. All sensors are constantly monitored by the Segway PT to ensure each is operating correctly. If one of these sensors fail, the Segway PT will perform a Safety Shutdown.

- ▶ ▶ For more information on Safety Shutdown, see **“Safety Shutdown” on page 55.**

Batteries

Figure 15 shows the location of the Batteries.

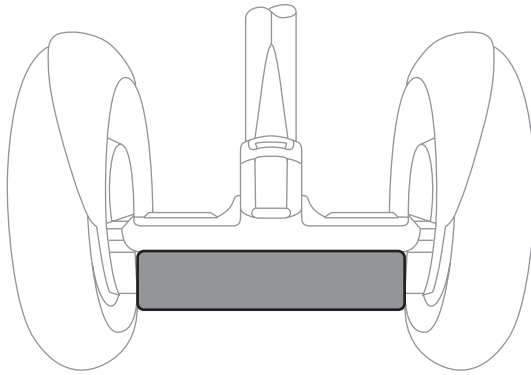

Figure 15. Location of Batteries

The two Batteries are sealed units (when properly installed) that require no maintenance other than proper charging and storage. The Batteries are interchangeable and can each be installed in either the front or rear of the Powerbase. For the Segway PT to operate, both Batteries must be installed, and both must be Li-ion Batteries. If one Battery fails or is depleted beyond its safe limit, the Segway PT will perform a Safety Shutdown.

- ▶ ▶ For more information on Safety Shutdown, see **“Safety Shutdown”** on page 55.

Chapter 3:

Understanding the Safety Alerts

This chapter describes the Segway PT's safety alerts. The safety alerts include:

- Speed Limiter
- Stick Shake Warning
- Safety Shutdown

It is important that you recognize these alerts and know how to respond appropriately before you ride your Segway PT.



WARNING!

Read and follow all the instructions in the Getting Started Manual, this Reference Manual and watch the Safety Video for important safety information about the Speed Limiter, Stick Shake, and Safety Shutdown safety alerts.



NOTE:

Not every safety issue triggers an alert. For additional safety tips and guidelines, see “**Avoiding Hazards**” in the Getting Started Manual.

Speed Limiter

When you approach the maximum allowed speed, the Segway PT's Speed Limiter will push the Handlebar back to slow you down. (see **Figure 16**).

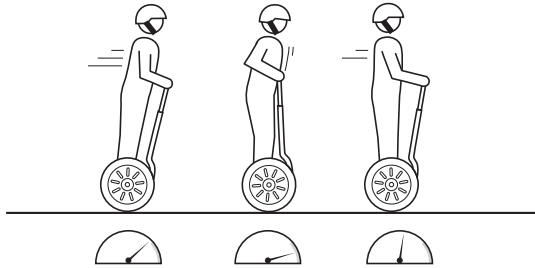

Figure 16. Speed Limiter

The Segway PT's Speed Limiter is an alert that you are moving too fast! When the Speed Limiter pushes the Handlebar back, **stop leaning forward and slow down**. Always leave a gap between yourself and the Handlebar as shown in **Figure 17**. Once you slow to a speed that the Segway PT determines is safe, it will resume normal operation and riding position.

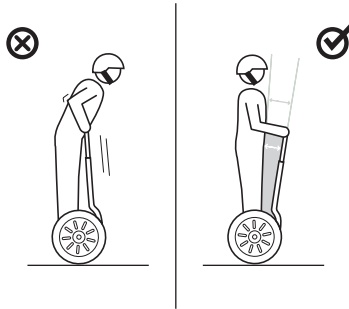

Figure 17. Gap Between Rider and Handlebar



WARNING!

Riding against the Handlebar can cause loss of control, collisions, falls, and injury.

The speed at which the Speed Limiter pushes the Handlebar back depends on a variety of factors including riding style, terrain, payload, whether or not the Beginner Setting is enabled, Battery condition, foot positioning, and other factors.



NOTE:

Conditions that may cause the Speed Limiter to activate and show the face icon with the straight mouth along with the Warning icon, when you are traveling at less than the maximum speed allowed for your operating mode include:

- Riding up a steep hill
 - Riding on bumpy terrain
 - Riding with fewer than three Rider Detect Sensors depressed
 - The first few seconds after you power on and step on the Powerbase
 - Low Battery charge
 - Batteries that are too hot or too cold
 - Riding down a hill with fully charged Batteries
Because of regenerative charging, if the Batteries are fully charged, the Segway PT will activate the Speed Limiter to avoid overcharging.
-

Table 5 shows the icons that display on the InfoKey Controller when the Speed Limiter is engaged at a speed lower than the top speed set by the InfoKey Controller. This table also describes the error that has occurred and the recommended action you should take.

Table 5. Speed Limiter (Display Icon and Recommended Action)

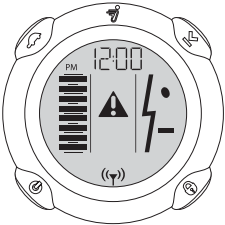
Display Icon	Description	Recommended Action
	<p>The Segway PT is operating at reduced performance levels due to a temporary condition. The speed limit has been lowered until the condition clears.</p>	<p>When the Speed Limiter pushes the Handlebar back, stop leaning forward and slow down. Always leave a gap between yourself and the Handlebar.</p>

Stick Shake Warning

One of the ways that the Segway PT notifies you when you are at risk of falling is by shaking the Handlebar and making growling noises. This is called the Stick Shake Warning. The Stick Shake Warning can occur in conjunction with, or independent of the Speed Limiter and Safety Shutdown alert, depending on your riding situation (see **Figure 18**).

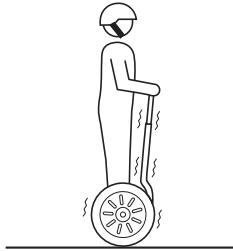

Figure 18. Stick Shake Warning

Rider On

If the Stick Shake Warning occurs while riding, slow down. If the Stick Shake Warning persists, come to a stop and safely step off. Do not attempt to ride again until the condition that caused the persistent Stick Shake Warning has been identified and corrected. If the Stick Shake Warning occurs while you are stopped or stuck, step off immediately and do not attempt to ride again until:

- You are clear of all obstacles and slopes.
- You are certain that you did not experience a Safety Shutdown.
 - ▶ ▶ For additional information, see **“Safety Shutdown” on page 55.**

When riding, the Stick Shake Warning occurs if you demand too much power from the Segway PT. The Stick Shake Warning can happen when riding on a steep slope, rough terrain, or against an obstacle, or when accelerating or decelerating abruptly. The Stick Shake Warning also occurs if you ride backward too fast or if you try to step on the Segway PT when it is not ready to balance. The Stick Shake Warning is more likely to occur when your Batteries are low, cold, heavily used, or poorly maintained because there is less energy available to keep you balanced.

Table 6 lists possible causes of the Stick Shake Warning and recommended actions to take when the Stick Shake Warning occurs with a Rider on the Mats.

Table 6. Stick Shake Warning With a Rider on the Mats

Possible Causes	Recommended Action
Riding aggressively, accelerating or stopping abruptly.	Ride more smoothly and slowly.
Riding against the Handlebar causing you to demand too much power.	Leave a gap between you and the Handlebar.
Riding on rough terrain or steep slopes causing you to demand too much power.	Ride on smoother, flatter, less demanding terrain. If on a slope, turn perpendicular to the slope, step off, and walk your Segway PT in Riderless Balance Mode.
Riding against an obstruction such as a door frame or curb that stops the Wheel while you continue to demand power.	Stop pushing against the obstruction. Stop, step off, and proceed by walking around the obstruction with the Segway PT in Riderless Balance Mode.
Riding backwards too quickly.	Stop, turn in place, and proceed forward.
Safety Shutdown has begun.	Come to a controlled stop and safely step off the Powerbase within 10 seconds.

Rider Off

You do not have to be riding the Segway PT for the Stick Shake Warning to occur. The Stick Shake Warning occurs if the Segway PT is moved too quickly while in Riderless Balance Mode. Riderless Balance Mode is when the Segway PT is in Balance mode without a rider standing on the Powerbase. The Stick Shake Warning also occurs if the Wheels spin as you pull the Segway PT over a curb or up stairs.

Table 7 lists possible causes of the Stick Shake Warning and recommended actions to take when the Stick Shake Warning occurs with no Rider on the Mats.

Table 7. Stick Shake Warning With No Rider on the Mats

Possible Causes	Recommended Action
Moving a Segway PT too quickly with no rider on the Powerbase while in Riderless Balance Mode.	When moving your Segway PT in Riderless Balance Mode, you must move slowly and carefully. Always keep the Segway PT below you (lead it up stairs or slopes and keep it below you when descending stairs or slopes).
Stepping on the Segway PT when it is powered on, but not ready to for you to step on.	Step off, center the LeanSteer Frame, and level the Powerbase. Once the center Balance Indicator light turns green, step on again.

Safety Shutdown

If the Segway PT detects a fault in any of its redundant systems or a Battery is depleted beyond its safe limit, it performs a Safety Shutdown (see **Figure 19**).

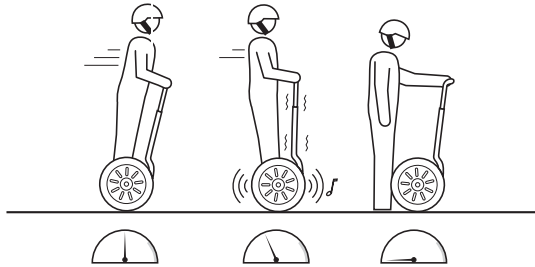

Figure 19. Safety Shutdown

When a Safety Shutdown occurs, the Segway PT automatically reduces its speed, gives the Stick Shake Warning (shakes the Handlebar and makes growling noises), flashes the Balance Indicator lights, emits a warning tone, and the InfoKey Controller displays an unhappy face.

You have approximately 10 seconds from the start of a Safety Shutdown to come to a controlled stop and step off. After 10 seconds, the Segway PT will immediately shut down when the Wheels reach zero speed.

If a Safety Shutdown occurs:

1. Immediately come to a controlled stop.
2. Carefully step off one foot at a time.



WARNING!

Never restart and ride your Segway PT after it has indicated an empty Battery condition or performed Safety Shutdown due to low Battery. The Segway PT may not have enough power to keep you balanced, especially if you demand a lot of power at once. If you restart and continue riding, you risk falling. Also, you risk damaging your Batteries, resulting in reduced Battery life and capacity. If the condition persists, contact an Authorized Segway Dealer or Distributor.



WARNING!

Theft detection systems, such as the type used in some libraries and retail stores can interfere with the Segway PT's ability to balance and/or cause the Segway PT to perform a Safety Shutdown. Do not ride within 5 feet (1.5 meters) of any theft detection system.

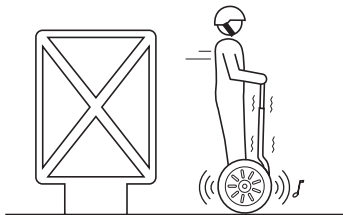
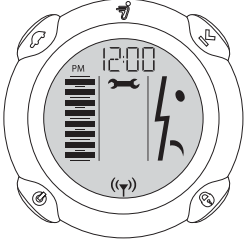

Table 8 shows the InfoKey Controller icon that displays when a Safety Shutdown occurs. The table also describes the recommended action you should take.

Table 8. Safety Shutdown (Icon and Recommended Action)

Display Icon	Description	Recommended Action
	<p>The system has detected a fault and is slowing to zero speed before shutdown (full Segway PT Battery charge level shown).</p>	<p>If a Safety Shutdown occurs:</p> <ol style="list-style-type: none"> 1. Immediately come to a controlled stop. 2. Carefully step off one foot at a time. You have approximately 10 seconds from the start of the Safety Shutdown to come to a controlled stop and step off the Powerbase. <p>Do not resume use of your Segway PT after a Safety Shutdown has occurred until you have identified and corrected the condition that caused it. See “Troubleshooting the Segway PT” on page 119.</p>

Empty Battery Condition

The Segway PT notifies you of a pending empty Battery condition before starting a Safety Shutdown.

An unhappy face icon displays on the InfoKey Controller, the Segway PT's speed is limited, and the Segway PT emits a warning tone.

Whenever the Segway PT notifies you of a pending empty Battery condition, come to a controlled stop and safely step off of the Segway PT before the Safety Shutdown begins.

Table 9 shows the InfoKey Controller icon that displays when a pending empty Battery notification occurs. The table also describes the recommended action you should take.

Table 9. Empty Battery Condition (Icon and Recommended Action)

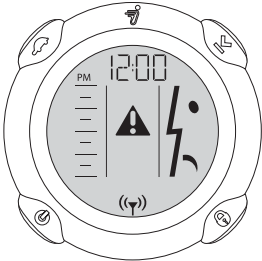
Display Icon	Description	Recommended Action
	The system has detected and notified you of a pending empty Battery condition.	Come to a controlled stop and safely step off of the Segway PT before the Safety Shutdown begins. Do not resume use of your Segway PT until you have charged the Batteries.



NOTE:

In some cases, old, cold, heavily used, or poorly maintained Batteries may develop a high resistance condition. This can cause a pending empty Battery condition to occur even if the Batteries were recently charged.

Chapter 4:

Using the Batteries

This chapter describes:

- Charging the Segway PT Batteries.
- Maintaining your Segway PT Batteries.
- Safety rules.
- Specifications.

Battery Safety



WARNING!

For your safety and the safety of others, and to maximize Battery life and performance, follow the instructions in this Manual.



WARNING!

Do not use the Batteries if the casing is:

- **Broken**
- **Emits an unusual odor or excessive heat**
- **Leaks any substance.**

Avoid contact with any substance seeping from the Batteries.

Keep Batteries out of reach of children and pets. Exposure to Battery voltage could result in death or serious injury.

Unplug and disconnect your Segway PT from AC power before removing or installing Batteries or performing any service. It is hazardous to work on any part of your Segway PT when it is plugged into AC power. You risk serious bodily injury from electric shock as well as damage to your Segway PT.

The cells within the Batteries contain toxic substances. Do not attempt to open Batteries. Do not insert any object into the Batteries or use any device to pry at the Batteries casing. If you insert an object into any of the Batteries' ports or openings you could suffer electric shock, injury, burns, or cause a fire. Attempting to open the Batteries casing will damage the casing and could release toxic and harmful substances.

Only charge the Batteries using charging devices approved by Segway.

Comply with all local and federal and individual country laws when disposing of and transporting the Segway PT Batteries.

Specifications for the Batteries

Table 10 lists the specifications for the Batteries.

Table 10. Specifications

Specification for Batteries	Li-ion-92 Cell
Charging Time	
Before First Use	12 hours
Recharge from Empty:	~8 hours
Temperature Ranges	
Operating	14°F to 122°F (-10°C to 50°C)
Charging	14°F to 122°F (-10°C to 50°C)
Storage and Transport	-4°F to 122°F (-20°C to 50°C)
General	
Capacity (Ah) and Voltage	5.8 Ah, 73.6 V~
Dimensions	14 x 7.5 x 3.2 in (35.7 x 19 x 8.2 cm)
Battery Pack Weight (pair)	22.7 lbs (10.3 kg)



NOTE:

If you use, charge, or store your Segway PT Batteries outside the limits specified, you may void the limited warranty, damage your Batteries, and/or experience reduced range and ineffective Battery charging.

Charging Your Batteries

To maximize the performance of your Segway PT Batteries, fully charge your Batteries for at least 12 hours, once a month, or after every 12 hours of operation—whichever comes first. Charge your Batteries only when they are within the specified charging temperature range

- ▶ ▶ For more information, see “**Specifications for the Batteries**” on page 63.

CAUTION

Failure to charge the Batteries could result in permanent damage to them. Left unplugged, the Batteries could fully discharge over time, causing permanent damage.

Use only charging devices approved by Segway.

Charging times vary depending on the following:

- Amount of charge already stored in the Batteries— The lower the Battery Charge Level is, the longer it will take to complete the charging process.
- Temperature of the Batteries— Batteries that are too hot or too cold may not charge or may take much longer to charge. Batteries charge most efficiently when they are close to the center of the recommended charging temperature range.
 - ▶ ▶ For more information, see “**Specifications**” on page 63).

To charge the Batteries:

1. Put your Segway PT in a clean, dry place, within the recommended charging temperature range.
2. Open the Charge Port on the back of your Segway PT's Console (see **Figure 20**).

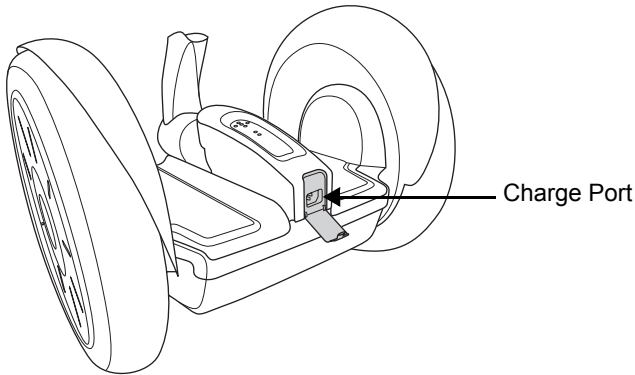

Figure 20. Open the Charge Port

3. Verify that the Charge Port, Power Cord and AC Power outlet are clean, dry, and free of debris.



WARNING!

Do not insert the plug if the Charge Port, Power Cord or AC Power outlet is wet.

4. Plug one end of the Power Cord (provided with your Segway PT) into a grounded AC outlet (100 V~ to 240 V~; 50 Hz or 60 Hz). The Power Cord should be properly grounded (see **Figure 21**).

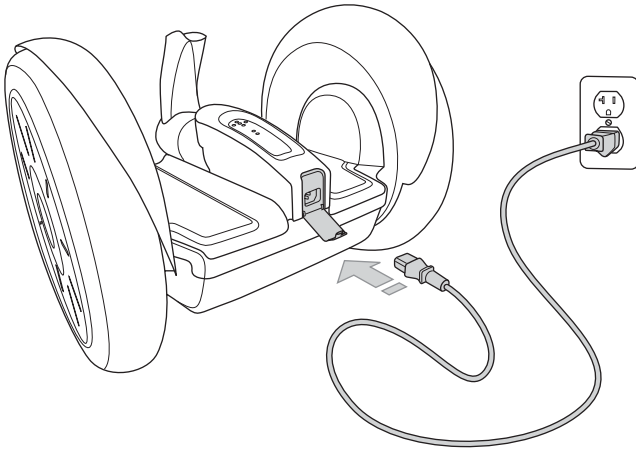

Figure 21. Plug Power Cord into Charge Port

5. Plug the other end of the Power Cord into the Charge Port.

6. Verify that the two Charge Indicator lights on the Console illuminate green to confirm the Batteries are charging (see **Figure 23**).

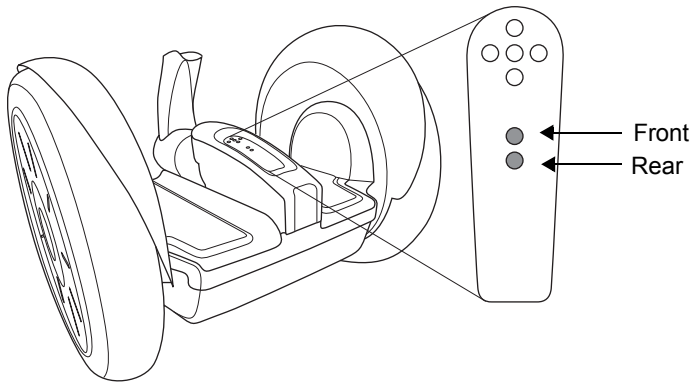

Figure 22. Location of Battery Charge Indicator Lights

- ▶ ▶ For more information on the Charge Indicator lights, see **“Battery Charge Indicator Lights”** on page **69**.



NOTE:

The Segway PT’s charging system is automatically controlled to prevent overcharging. Plug your Segway PT into a grounded AC power outlet when it is not in use, even if you do not plan to use it for an extended period of time.

Unplugging the Segway PT

When you are ready to use your Segway PT, remove the Power Cord, then close the Charge Port Cover as follows:

1. Disconnect the Power Cord from the Charge Port on the Segway PT.
2. Disconnect the Power Cord from the grounded AC outlet.
3. Store the Power Cord.
4. Close the Charge Port Cover.



Always keep the Charge Port Cover closed, except when you are charging the Segway PT.

Closing the Charge Port Cover prevents water, dirt, dust, and other contaminants from entering the Charge Port and causing damage to your Segway PT.

Battery Charge Indicator Lights

Two Charge Indicator lights on the Console indicate the charge status of the Batteries when the Segway PT is plugged in. The front Charge Indicator light corresponds to the front Battery and the rear Charge Indicator light corresponds to the rear Battery (see **Figure 23**).

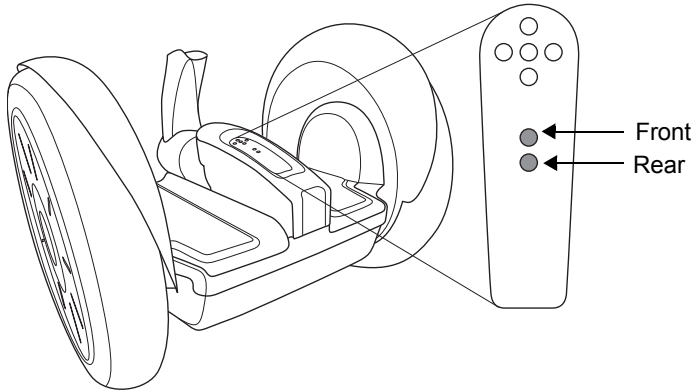

Figure 23. Location of Battery Charge Indicators

The Charge Indicator lights provide independent information regarding whether each Battery is charging.

When the Segway PT is plugged in and charging, both Charge Indicator lights will be flashing or solid green.

If one or both Charge Indicator lights is red or fails to illuminate, there is a charging problem with the corresponding Battery.

- ▶ ▶ For more information, see “**Charging Failures**” on **page 70**.

Charging Failures

If a failure is detected during charging, all charging will stop. Depending on the nature of the failure, a solid red Charge Indicator light displays or the Charge Indicator light is off.

If either or both Charge Indicator lights are red or off, check the following:

1. If the Charge Indicator lights are off (no illumination), check that AC power is present, and ensure the Power Cord is full seated in the Charge Port.
2. If AC power is present and the Charge Indicator lights are either red or off, unplug the power cord, then remove and reseat the Battery Pack(s).
 - ▶ ▶ For instructions, see **“Removing the Batteries” on page 100** and **“Reattaching the Batteries” on page 102**.
3. If these actions fail to resolve the problem, contact an Authorized Segway Dealer or Distributor.

Regenerative Braking

The Segway PT has a regenerative braking system that charges the Batteries when descending a hill or slowing down.

When you ride down a hill, you may notice an increase in the Battery charge level. If your Batteries are already completely full at the top of a hill, when you descend, you may feel the Speed Limiter engage to keep the Segway PT from overcharging its Batteries.

- ▶ ▶ For more information on the Speed Limiter, see **“Safety Shutdown” on page 55**.

Reading the Battery Charge Level Display

The horizontal bars on the left side of the InfoKey Controller display indicate the levels of the charge in the Segway PT Batteries. **Figure 24** shows how the Segway PT Battery Gauge on the InfoKey Controller changes as the Battery is depleted.

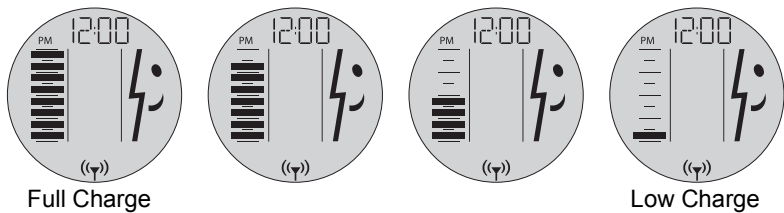

Figure 24. InfoKey Controller Display with Battery Charge Being Depleted

The more charge the Batteries contain, the more horizontal bars are shown. If the Battery charge level is very low, the Segway PT will notify you of a pending empty Battery condition prior to initiating Safety Shutdown.

- ▶ ▶ For more information, see **“Safety Shutdown” on page 55.**

Do not ride your Segway PT if there is inadequate charge in the Batteries (indicated by the unhappy face icon on the InfoKey Controller and no dark horizontal lines on the Battery Charge display). Carefully monitor your Segway PT Battery Gauge and be prepared to stop off if your Battery charge becomes completely depleted.

Surface Charge (Partial Charge)

Whenever you do not fully charge the Segway PT's Batteries, surface charge or partial charge may affect the accuracy of the Battery charge level display, causing it to show a higher charge level than actually exists.

After you power on, check the Battery charge level display and then ride for at least three or four minutes and check the Battery charge level display again. If the Battery charge level display shows rapid charge depletion during this time, the Batteries have received only a surface charge. If necessary, plug the Segway PT back in and recharge.

Recalibrating the Display

The Segway PT indicates the Battery charge level in the InfoKey Controller, as described in “**Reading the Battery Charge Level Display**” on page 71.

The display may be inaccurate after long periods of storage, or during initial use. To recalibrate the display:

1. Fully charge the Batteries for 12 hours.
2. Discharge the Batteries until the bottom bar in the Display is blinking (approximately 10 percent Battery charge remaining).

The InfoKey Controller will display the following:

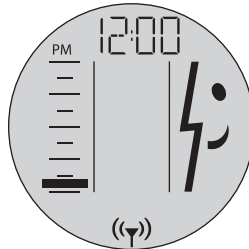

3. Leave your Segway PT in a safe, secure location, powered on, until the Battery charge is fully depleted, and your Segway PT powers down.



NOTE:

Depleting your Segway PT Batteries from the bottom bar to empty could take several hours, depending on Battery condition and the amount of charge remaining.



WARNING!

Do not ride your Segway PT to full Battery depletion. To safely discharge Batteries below the bottom bar, you should leave your Segway PT powered on in Balance Mode leaning against a wall in a secure location.



CAUTION

To avoid injury, damage, and to deter theft, be sure your Segway PT discharges in a safe, secure location, powered on in Riderless Balance Mode.

4. Fully recharge the Batteries for a minimum of 12 hours, after which the Battery Charge Level Display will be recalibrated.

How Temperature Affects Performance

The Batteries are usually significantly warmer than the air temperature due to heating that occurs as electricity is delivered from them (while riding) and to them (while charging.)

Riding in Hot or Cold Temperatures

The Batteries will run at the highest efficiency when you operate them nearest the center of the recommended operating temperature range.

If the Batteries on your Segway PT become too hot or too cold while riding, the Segway PT may activate a safety alert.

- ▶ ▶ For more information, see “**Understanding the Safety Alerts**” on page 47.

Table 11 shows the InfoKey Controller icon that displays when your Segway PT Batteries become too hot or too cold.

Table 11. Riding in Hot and Cold Temperatures (Icon and Recommended Action)

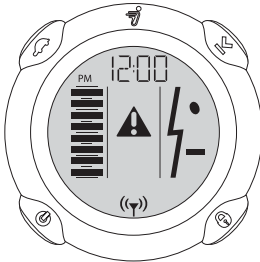
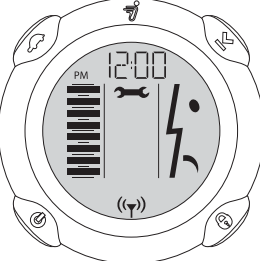
Display Icon	Description	Recommended Action
 <p>The display shows a battery level indicator on the left, the time 12:00 PM at the top, a warning triangle with an exclamation mark in the center, and a lightning bolt on the right. There are also directional arrows around the display frame.</p>	<p>Speed Limiter or Stick Shake Warning</p>	<p>Respond as instructed in Chapter 3, “Understanding the Safety Alerts.”</p> <p>Allow your Batteries to warm or cool to within the recommended operating temperature range prior to riding. For more information, see “Temperature Ranges” on page 63.</p>
 <p>The display shows a battery level indicator on the left, the time 12:00 PM at the top, a wrench icon in the center, and a lightning bolt on the right. There are also directional arrows around the display frame.</p>	<p>Safety Shutdown</p>	<p>Respond as instructed in Chapter 3, “Understanding the Safety Alerts.”</p> <p>Allow your Batteries to warm or cool to within the recommended operating temperature range prior to riding. For more information, see “Temperature Ranges” on page 63.</p>

As with all batteries, less energy is available at low battery temperatures. You may not be able to travel the same distance when the Batteries are cold, as when the Batteries are nearer to room temperature.

Charging in Hot or Cold Temperatures

Your Batteries should be within the recommended charging temperature range prior to and during charging.

- ▶ ▶ For the recommended Battery charging temperature range, see “**Temperature Ranges**” on page 63.

The Batteries will charge most efficiently when they are nearest the center of the recommended charging temperature range.

If your Batteries are too hot or too cold, they may take longer to charge, or they may not charge at all.

- ▶ ▶ If you are concerned that the Batteries may be too cold or overheated during charging, see “**Charging Failures**” on page 70.

Replacing Batteries

Your Segway PT is powered by two rechargeable Li-ion Batteries. With normal usage and proper maintenance, Batteries should last the equivalent of 600 to 1000 full charges. As your Batteries near the end of their useful life, they need more frequent charging and your Segway PT's range will be reduced. To order replacement Batteries, contact an Authorized Segway Dealer or Distributor.

Replacing Batteries in Pairs

Whenever you need to replace a Battery, consider replacing both Batteries, and always use pairs of Batteries with the same chemistry. Replacing only one Battery will not necessarily increase the performance or range of your Segway PT, because the Segway PT is designed to operate only at the level allowed by the lower-energy Battery.

Redundancy is a critical safety feature built into the Segway PT that also applies to the Batteries. Therefore, you should replace Batteries in pairs (except for the unusual situation where a Battery is replaced because of damage or defect and the other Battery is relatively new).

- ▶ ▶ For information on removing and reseating Batteries, see **“Removing the Batteries”** on page 100 and **“Reattaching the Batteries”** on page 102.

Transporting and Shipping Batteries

If you are transporting your Segway PT, protect the Batteries to avoid damage during shipment. Do not expose the Batteries to direct heat or moisture, and avoid heavy vibration during transportation.



WARNING!

Do not use or transport a Battery if the casing breaks open, leaks any substance, becomes excessively hot, or if you detect an unusual odor.

Do not handle a damaged or leaking Battery unless you are wearing disposable rubber gloves, eye protection, and are in a well-ventilated area. Dispose of the rubber gloves and damaged Battery properly in accordance with regulations governing disposal of toxic materials.

Shipping Li-ion Batteries

This section provides guidelines for shipping your Segway PT and the associated Batteries.

Table 12 lists the shipping methods allowed for Li-ion Batteries



WARNING!

Li-ion Batteries are considered Hazardous Materials under shipping regulations. Comply with all local, federal and individual country laws when transporting the Segway PT Batteries.

Table 12. Shipping Li-ion Batteries

	Ground	Sea	Air
Batteries Installed	Allowed	Allowed	Not allowed. Hazardous Materials regulations apply. *
Batteries Not Installed	Not allowed. Hazardous Materials regulations apply.*		
* Contact an Authorized Segway Dealer or Distributor, or refer to www.segway.com .			

If you need to arrange air shipment of your Segway PT with Li-ion Batteries installed, or if you need to arrange shipment of your Li-ion Batteries separate from the Segway PT by any means of transport, contact Segway or an Authorized Segway Dealer or Distributor for detailed information on shipping of hazardous materials.

Chapter 5:

Operating and Maintaining Your Segway PT

The Segway PT is designed to be virtually maintenance free. Make sure it is clean, all parts are installed and functioning properly, Batteries are charged, and Tires are properly inflated prior to riding. Never open the Console, Powerbase or Gearboxes. These are not user-serviceable parts.

This chapter describes:

- General maintenance procedures related to your Segway PT.
- Important operating tips.



WARNING!

Before you perform any of the following procedures, verify that the Segway PT is powered off and unplugged. It is not safe to perform these procedure while the Segway PT is powered on or charging.

Lifting Your Segway PT

Use proper techniques to safely lift and load your Segway PT.

Segway recommends that two people work together to lift the Segway PT. To lift the Segway PT:

1. Make sure the Segway PT is unplugged and powered off.
2. Select firm, non-moving lifting points such as the Powerbase or lower cargo frames if provided.
3. Lift the Segway PT with your legs, not your back. See **Figure 25**.

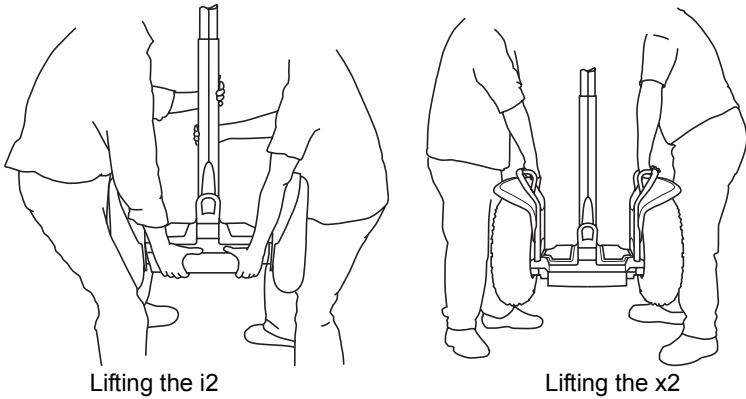

Figure 25. Lifting the Segway PT



WARNING!

Watch Your Fingers! Never lift the Segway PT by its Tires, Fenders, or Wheels because your hands or fingers could become caught between the Tire and the Fender, resulting in injury.

Maintaining Tires and Wheels

To ensure safe and efficient operation of your Segway PT, be sure to check Tires and Wheels regularly, especially if you have recently performed service on a Tire/Wheel Assembly.

Checking the Tire/Wheel Assembly

To check the Tires and Wheels:

1. Make sure the Segway PT is unplugged and powered off.
2. Check for Wheel wobble by grasping the Tire/Wheel Assembly and attempt to move it side-to-side. The Tire/Wheel Assembly should not move laterally. If you detect Wheel wobble, check the Wheel nut and tighten if necessary.
 - ▶ ▶ For additional information regarding service procedures for the Tire/Wheel Assembly, see **“Installing the Tire/Wheel Assembly” on page 107.**

Checking Tire Inflation Pressure

The Tires on the Segway PT provide suspension and traction. Both functions are affected by the tire inflation pressure. Be sure to:

1. Make sure the Segway PT is unplugged and powered off.
2. Check tire inflation pressure regularly. Improperly inflated Tires will result in less than optimal range.
3. If tire inflation pressure in either Tire is not at the level stated in the **“Segway PT Specifications” on page 5** for your Segway PT model, inflate the Tire to the specified pressure.
4. Check that both Tires are inflated equally and are free of debris or contaminants.



WARNING!

The tire pressure stated on any affixed Wheel label (near the inflation valve) supersedes any recommended pressure stated on the Tires.

Higher pressure reduces suspension performance and traction, and increases risk of loss of control, collisions, and falls.

Lower pressure reduces range and increases risk of damage to the Tire/ Wheel Assembly.

Unequal pressure causes the Segway PT to turn in the direction of the lower pressure tire.

Cleaning Your Segway PT

To clean your Segway PT:

1. Make sure the Segway PT is unplugged and powered off.
2. Always close the Charge Port Cover after charging, and prior to cleaning.
3. Gently clean your Segway PT with soap and water and a soft cloth.

Avoid Submerging Your Segway PT

Submerging your Segway PT can cause permanent damage (see Figure 26).

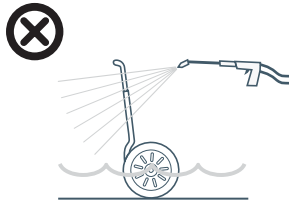

Figure 26. Avoid Submersion

Observe the following rules regarding submersion and water:

- Do not submerge the Batteries or Powerbase in water.
- Avoid exposure to heavy downpours or extended periods of heavy rain (when riding, storing, or transporting the Segway PT).

CAUTION

Do not use a power washer or high pressure hose to clean your Segway PT. Use of these devices could force water into components that must stay dry.

Do not allow water to get into the Charge Port.

WARNING!

Do not clean the Mat or Tires with any specialized cleaners. Use of such products may reduce traction.

Storing Your Segway PT

To maximize the performance of your Segway PT Batteries, fully charge your Batteries for at least 12 hours, once a month, or after every 12 hours of operation—whichever comes first. Charge your Batteries only when they are within the specified charging temperature range.

Store your Segway PT (and its Batteries) indoors, in a place that is free of moisture, humidity, and temperature extremes. Even if you will not be using your Segway PT for an extended period of time, you should leave it plugged into AC power. Otherwise the Batteries could fully discharge over time, causing permanent damage.

Store your Segway PT within the recommended charging and storage temperature ranges, as shown in **Table 10 on page 63** to preserve the full performance capabilities of the Segway PT Batteries.

 **CAUTION**

Failure to charge the Batteries could result in permanent damage to them. Left unplugged, the Batteries could fully discharge over time, causing permanent damage.

Use only charging devices approved by Segway.

Chapter 6:

Servicing Your Segway PT

This chapter describes how to service your Segway PT.

General Information



WARNING!

Always shut down your Segway PT and unplug the AC Power Cord before performing any maintenance or installing any part or accessory.



WARNING!

Do not attempt to open the Powerbase or Console. There are no user-serviceable parts inside. By opening the Powerbase or Console, you risk electric shock injury. Also, you could void your limited warranty, damage your Segway PT, and render it unsafe to use.

Do not attempt to open the Gearboxes. There are no user-serviceable parts inside. You could damage your Segway PT and render it unsafe to use.

Parts Diagram

Figure 27 shows a parts diagram for the Segway PT (models i2, x2).

i2 Exploded View



x2 Exploded View



Figure 27. Parts Diagram for Segway PT (models i2, x2)

If you have a question on parts or replacements, please contact an Authorized Segway Dealer or Distributor. For a list of Dealers and Distributors, visit www.segway.com.

Replacing Parts

If a part breaks or needs replacement, contact an Authorized Segway Dealer or Distributor. Certain parts are user-replaceable. Use only Segway-provided replacement parts and fasteners. See your Segway PT Limited Warranty for a list of owner-replaceable parts.

Torque Specifications



Adhere to torque specifications when tightening fasteners. Over-tightening or under-tightening fasteners can result in damage or malfunction.

Accessories

If you are interested in adding accessories to your Segway PT, please contact an Authorized Segway Dealer or Distributor or visit www.segway.com to learn what accessories are available.

Service Procedures

Use the following procedures when instructed to do so by the Troubleshooting section of this Reference Manual. The tools provided with your Segway PT are intended to assist with these procedures. However, additional tools, such as a torque wrench, will be necessary to perform some of these procedures correctly.

Removing the LeanSteer Frame

Tool Required: 5mm hex wrench.

To remove the LeanSteer Frame from the base:

1. Make sure the Segway PT is unplugged and powered off.
2. Using a 5mm hex wrench, remove the fastener holding the LeanSteer Frame in place. See **Figure 28**.

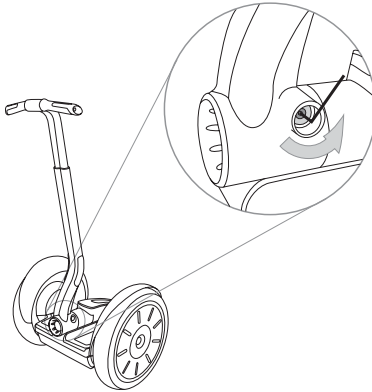

Figure 28. Loosen Fastener Holding LeanSteer Frame

3. Lean the LeanSteer Frame all the way to the left and right until the LeanSteer Frame is loose. You may hear and feel a click when the Wedge Clamp Assembly releases from the Pivot Base Assembly. See **Figure 29**.



Figure 29. Releasing the Handlebar/LeanSteer Frame from the Pivot Base Assembly

- Slide the LeanSteer Frame away from the Pivot Base Assembly as shown in **Figure 30**. Sliding the LeanSteer Frame away from the Pivot Base Assembly should require minimal force.

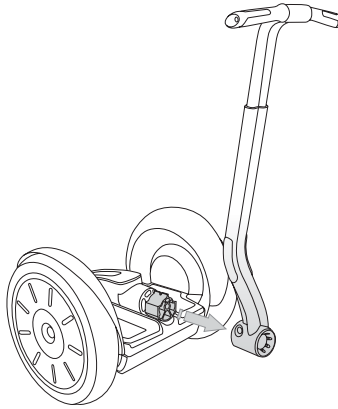

Figure 30. Remove the Handlebar/LeanSteer Frame from the Pivot Base Assembly

- If the Wedge Clamps fall out or are removed during this procedure, put them aside in a safe place as you will need them to reattach the LeanSteer Frame to the Powerbase.

Attaching the LeanSteer Frame

Tool Required: Torque wrench with 5mm bit.

To attach the LeanSteer Frame to the Powerbase:

1. Make sure the Segway PT is unplugged and powered off.
2. Slide the LeanSteer Frame onto the Pivot Base Assembly, as shown in **Figure 31**:

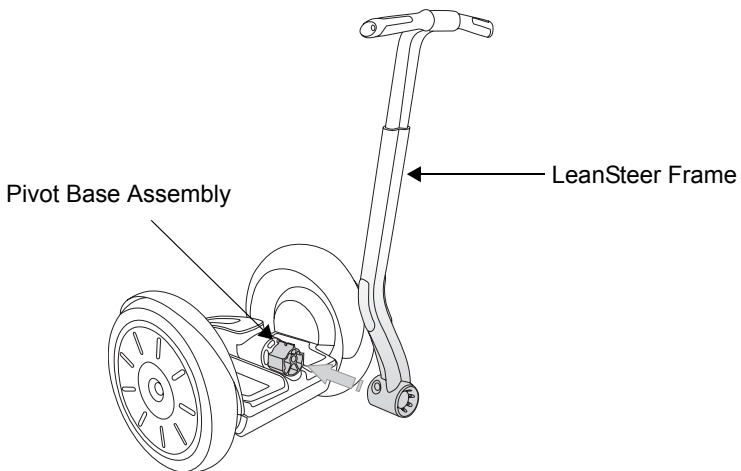

Figure 31. Attach Handlebar/LeanSteer Frame to the Pivot Base Assembly

3. If the Wedge Clamps are not installed, install each Wedge Clamp, curved side facing down, on either side of the LeanSteer Frame base.
4. Loosely thread in the fastener.

5. Prior to tightening the fastener, visually check that the Handlebar is straight and centered. If it is not straight and centered, adjust the LeanSteer Frame to straighten and center it.
6. Tighten the fastener to 11.0 N-m (8.1 ft-lbf). See **Figure 32**.

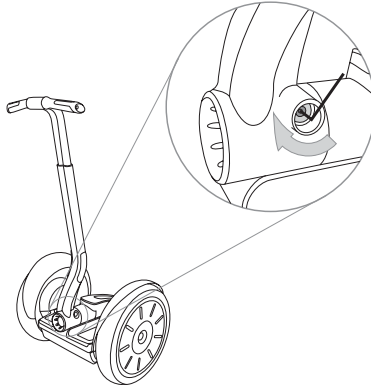

Figure 32. Tighten Fastener Holding LeanSteer Frame in Place

Removing the Handlebar

Tool Required: 3mm hex wrench.

To remove the Handlebar from the LeanSteer Frame:

1. Make sure the Segway PT is unplugged and powered off.
2. Using the 3mm hex wrench, remove the 3 fasteners that secure the Handlebar Clamp to the LeanSteer Frame.
3. When you remove these fasteners and the Handlebar Clamp, the Handlebar is released from the LeanSteer Frame (see **Figure 33**).

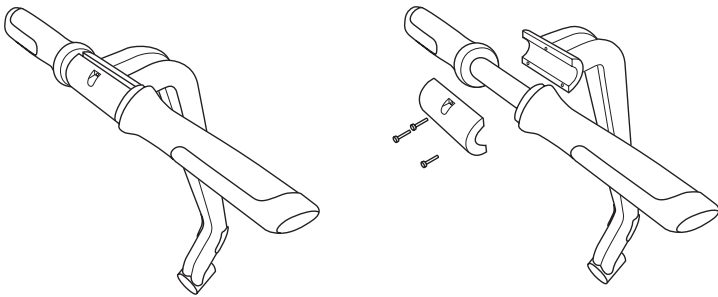

Figure 33. Remove Handlebar from the LeanSteer Frame

Attaching the Handlebar

Tool Required: Torque wrench with 3mm bit.

To attach the Handlebar to the LeanSteer Frame:

1. Make sure the Segway PT is unplugged and powered off.
2. Align the Handlebar in place against the LeanSteer Frame using the alignment guides. See **Figure 34**.
3. Position the Handlebar Clamp against the Handlebar.
4. Insert the 3 fasteners through the Handlebar Clamp into the LeanSteer Frame.
5. Using the 3mm hex wrench, alternate between the 3 fasteners, evenly tightening in small increments until the full torque setting of 6.0 N-m (4.4 ft-lbf) is achieved.
6. Check to ensure that the gap between the Handlebar Clamp and the LeanSteer Frame is even, and the same between the top and bottom.

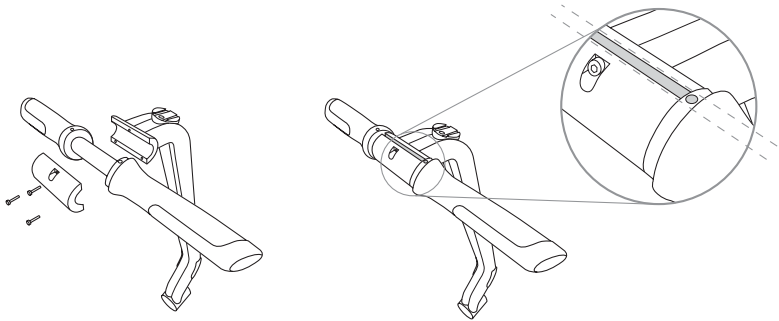

Figure 34. Secure Handlebar to LeanSteer Frame

Removing the Batteries

Tool Required: 3mm hex wrench.



WARNING!

Before you begin, verify that the Segway PT is powered off and unplugged. It is not safe to perform this procedure while the Segway PT is powered on or charging.

The cells within the Batteries contain toxic substances. Do not attempt to open Batteries. Do not use the Batteries if the casing is broken or if it emits an unusual odor or excessive heat or leaks any substance. Do not handle a damaged or leaking Batteries unless you are wearing disposable rubber gloves, eye protection, and are in a well-ventilated area. Dispose of rubber gloves and damaged Batteries properly in accordance with regulations governing disposal of toxic materials.

To remove the Batteries:

1. Make sure the Segway PT is unplugged and powered off.
2. Tip the Segway PT onto its side so that the Wheel lies flat against a smooth clean surface. See **Figure 35**.
3. Using the 3mm hex wrench, remove the fasteners which hold the Batteries in place (4 per Battery).
4. Pull Batteries straight off chassis.

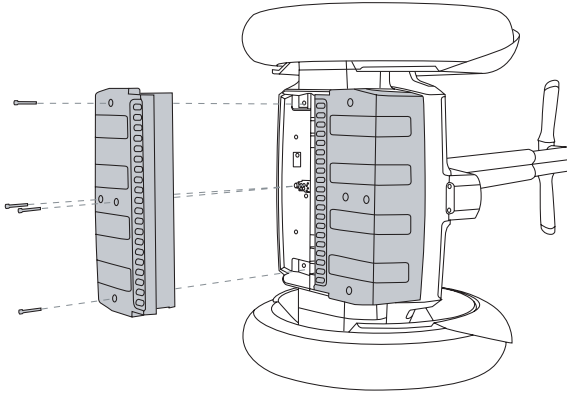

Figure 35. Removing the Batteries

Reattaching the Batteries

Tool Required: Torque wrench with 3mm bit.



WARNING!

Before you begin, verify that the Segway PT is unplugged. It is not safe to perform this procedure while the Segway PT is connected to AC power.

The cells within the Batteries contain toxic substances. Do not attempt to open Batteries. Do not use the Battery Pack if its casing is broken or if it emits an unusual odor or excessive heat or leaks any substance. Do not handle a damaged or leaking Battery Pack unless you are wearing disposable rubber gloves, eye protection, and are in a well-ventilated area. Dispose of rubber gloves and damaged Battery Pack properly in accordance with regulations governing disposal of toxic materials.

1. Make sure the Segway PT is unplugged and powered off.
2. Reseat one of the Batteries on the Powerbase with curved edge facing out, as shown in **Figure 36**.

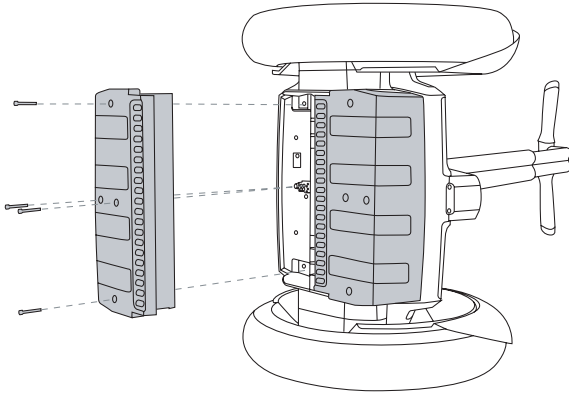

Figure 36. Reattaching the Batteries

3. Ensure the Battery is aligned straight against the edge of the Powerbase trim, and there are no uneven gaps.
4. Install and tighten the 2 center fasteners with the 3mm hex wrench to 1.0 N-m (9 in-lbf)
5. Install and tighten the 2 outer fasteners with the 3mm hex wrench to 1.0 N-m (9 in-lbf)
6. Ensure the Battery is aligned straight against the edge of the Powerbase trim, and there are no uneven gaps.
7. Repeat Steps 1 through 7 for the second Battery.

⚠ CAUTION

To avoid risk of damage, do not use a power tool to install or tighten fasteners.

Checking Tire Inflation Pressure

Tools Required: Low pressure tire gauge

To check the Tire inflation pressure for the i2 (the valve stem is not readily visible on the i2):

1. Make sure the Segway PT is unplugged and powered off.
2. Tip the Segway PT onto its side, making sure the Tire to be checked is on the ground. See **Figure 37**.

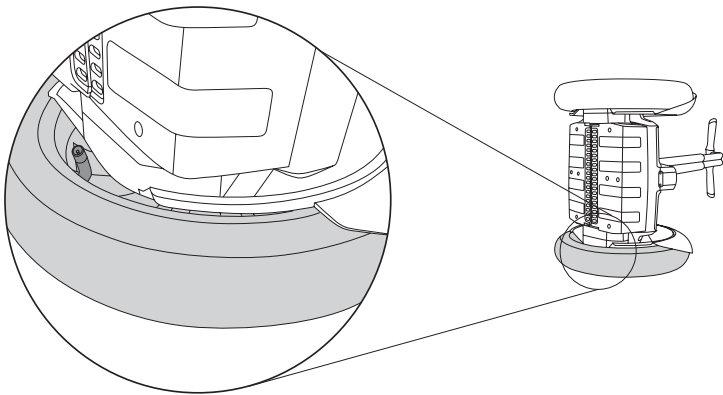

Figure 37. Check Tire Inflation Pressure

3. Rotate the Powerbase until the valve stem on the inside of the Wheel becomes visible.
 4. Check the Tire inflation pressure.
 - ▶ ▶ For more information, see **“Tire Inflation Pressure” on page 5.**
-



NOTE:

The valve stem is visible on the x2. You do not need to tip the x2 on its side to check or adjust Tire inflation pressure.



WARNING!

Inflate Tires to the correct pressure, as stated in the “Segway Specifications” on page 5. Overinflating or under inflating Tires can increase your risk of traction loss, resulting in injury and falls.

Removing the Tire/Wheel Assembly

Tools Required: 13mm socket wrench

To remove the Tire/Wheel assembly (see **Figure 38**):

1. Make sure the Segway PT is unplugged and powered off.

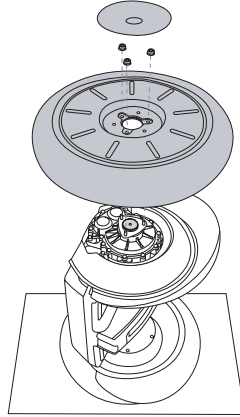

Figure 38. Removing Tire/Wheel Assembly

2. Tip the Segway PT onto its side so the Wheel you want to remove is facing up, and the other Wheel rests against a clean, smooth surface.
3. Remove the Wheel Cap by pressing down on the outside edge, and lifting the opposite outside edge with your fingers or a plastic wedge.
4. Remove the 3 Wheel Nuts with a 13mm socket wrench. Hold the Wheel to keep it from rotating.
5. Lift off the Wheel.
6. Clean all debris from the Wheel's mounting surfaces.

Installing the Tire/Wheel Assembly

Tools Required: 13mm socket, torque wrench

To install the Tire/Wheel assembly (see **Figure 39**):

1. Make sure the Segway PT is unplugged and powered off.

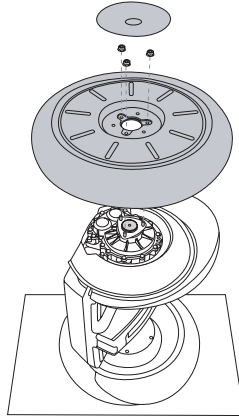

Figure 39. Reseating Tire/Wheel Assembly

2. Tip the Segway PT onto its side so the Wheel you want to remove is facing up, and the other Wheel rests against a clean, smooth surface.
3. Clean all debris from the Wheel's mounting surfaces.
4. Place the Tire/Wheel assembly over the 3 threaded posts.
5. Hold the Wheel to prevent it from rotating.
6. Thread on the 3 Wheel Nuts, and tighten to 35 N-m (26 ft-lbf) with a 13mm socket.
7. Replace the Wheel Cap by aligning the three plastic fittings on the underside of the Wheel Cap with the 3 holes in the Wheel.
8. Press down until the Wheel Cap snaps into place.

Removing/Installing the Fenders

Tools Required: T15 six-lobe wrench, Torque wrench with T15 six-lobe bit.

To remove the Fenders (see **Figure 40**):

1. Make sure the Segway PT is unplugged and powered off.
2. Remove the Tire/Wheel Assembly.
 - ▶ ▶ For more information, see “**Removing the Tire/Wheel Assembly**” on page 106.
3. Using a T15 six-lobe wrench, remove the 4 fasteners which attach the Fender to the Gearbox.
4. Remove the Fender.

To install the Fenders (see **Figure 40**):

1. Position the Fender so it aligns with the holes in the Gearbox.
2. Thread the 4 fasteners through the Fender to the Gearbox and tighten to 1.6 Nm (1.2 ft-lb).
3. Reseat the Tire/Wheel Assembly.
 - ▶ ▶ For more information, see “**Installing the Tire/Wheel Assembly**” on page 107.

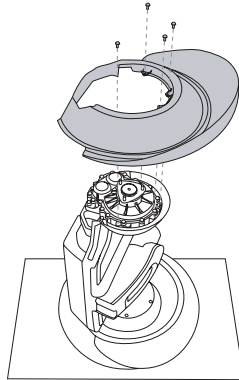

Figure 40. Servicing the Fenders

Removing/Installing the Mats

Tools Required: None.

To remove a Mat:

1. Make sure the Segway PT is unplugged and powered off.
2. Lift the Mat off the Powerbase.

To install a Mat:

1. Make sure the Segway PT is unplugged and powered off.
2. Verify that the top of the Powerbase and bottom of Mat are clean, dry, and free of debris.
3. Place a Mat on the Powerbase. See **Figure 41**.
4. Fit the Mat's rubber tabs into the Powerbase grooves.
5. Tuck the tabs in place around the entire perimeter of the Mat while you press down.
6. Visually confirm that the Mat is properly aligned and all rubber tabs are tucked in prior to riding.

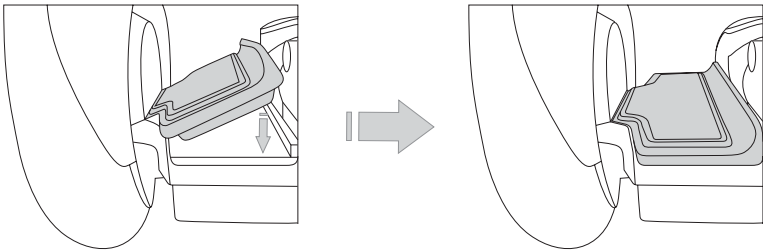

Figure 41. Removing and Installing the Mats

Replacing the InfoKey Controller Battery

Tool Required: Coin or Flathead Screwdriver.

To replace or reseal the InfoKey Controller battery:

1. Remove the InfoKey Controller from the Dock and unscrew the InfoKey Controller Dock Adapter.
 - ▶ ▶ For more information, see “**Docking/Undocking the InfoKey Controller**” on page 116.
2. Using a coin or a flathead screwdriver, unscrew the back cover of the InfoKey Controller. See **Figure 42**.

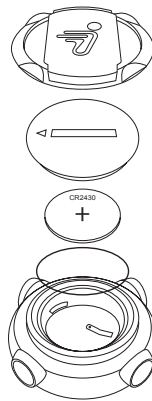

Figure 42. Replacing or Resealing the InfoKey Controller Battery

3. Remove the InfoKey Controller battery.

4. If you are replacing the battery, verify that the new battery is type CR2430. CR2430 replacement batteries are available at Electronics stores.
-



NOTE:

A spare InfoKey Controller battery ships with your new Segway PT, stored beneath the Console Trim. If you use this spare, you should replace it as soon as possible, as you cannot operate your Segway PT without a functioning InfoKey Controller.

- ▶ ▶ For more information, see **“Removing/Replacing the Console Trim” on page 112.**
-

5. Insert the InfoKey Controller battery with the positive (+) side showing.
6. Screw on the InfoKey Controller's back cover.
7. Screw on the InfoKey Controller Dock Adapter.

Removing/Replacing the Console Trim

Tool Required: None

To remove or replace the Console Trim:

1. Make sure the Segway PT is unplugged and powered off.
2. Pull up on the rigid plastic Console Trim located on the Console and between the Mats. See **Figure 43**.
3. Replace the Console Trim by pressing it back in place over the Console, then snapping the rear part of the Trim in place.



WARNING!

Do not attempt to open the Console. There are no user-serviceable parts inside. By opening the Console, you risk electric shock injury. Also, you could void your limited warranty, damage your Segway PT, and render it unsafe to use.

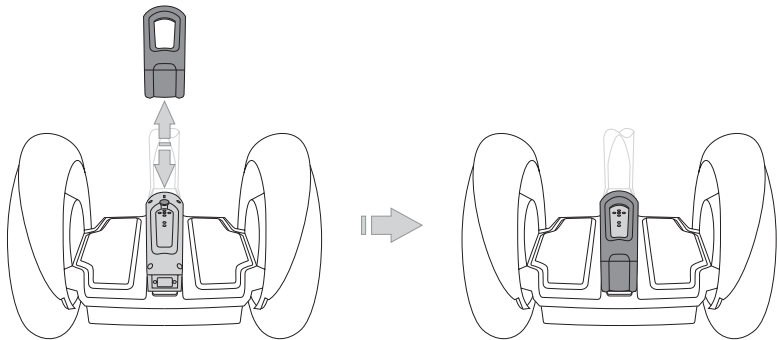

Figure 43. Removing or Replacing the Console Trim

Installing/Removing the InfoKey Controller Dock

Tool Required: 3mm hex wrench, Torque wrench with 3mm bit.

To install the InfoKey Controller Dock:

1. Make sure the Segway PT is unplugged and powered off.
2. Place the InfoKey Controller Dock against the upper LeanSteer Frame with the Release Tab oriented at the bottom, as shown in **Figure 44**.
3. Thread the 3mm fastener through the hole in the top of the InfoKey Controller Dock and into the upper LeanSteer Frame.
4. Tighten the fastener to 2.0 N-m (18 in-lbf).

To remove the InfoKey Controller Dock:

1. Make sure the Segway PT is unplugged and powered off.
2. Using a 3mm hex wrench, remove the fastener which holds the InfoKey Controller Dock to the LeanSteer Frame.
3. Remove the InfoKey Controller Dock.

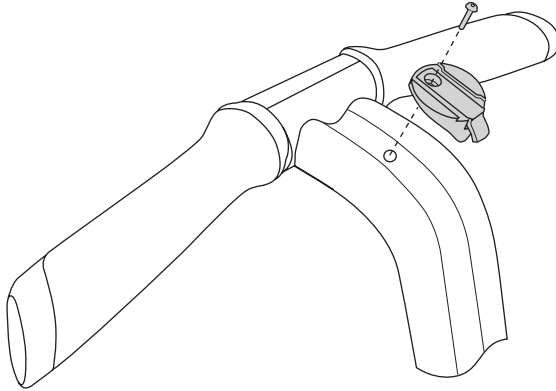

Figure 44. Installing or Removing the InfoKey Controller Dock

Installing/Removing the Dock Adapter

Tool Required: None.

To install the InfoKey Controller Dock Adapter, screw the adapter to the underside of the InfoKey Controller. When installed properly, the Dock Adapter should snap into place when screwed on.

To remove the InfoKey Controller Dock Adapter, unscrew the adapter from the underside of the InfoKey Controller.

Docking/Undocking the InfoKey Controller

Tool Required: None.

To Dock the InfoKey Controller:

1. Make sure the InfoKey Controller Dock Adapter is installed.
 - ▶ ▶ For more information, see “**Installing/Removing the Dock Adapter**” on page 115.
2. Slide the InfoKey Controller up into the InfoKey Controller Dock as shown in **Figure 45**.

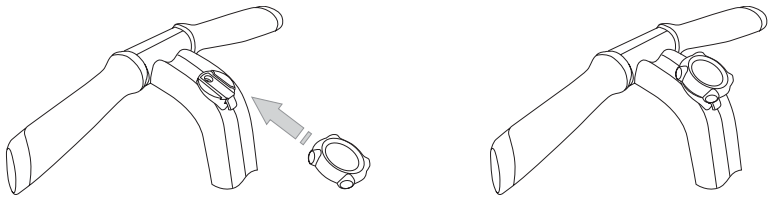

Figure 45. Docking the InfoKey Controller

To Undock the InfoKey Controller:

1. Press the Release Tab at the bottom of the InfoKey Controller Dock.
2. Slide the InfoKey Controller out of the InfoKey Controller Dock as shown in **Figure 46**.

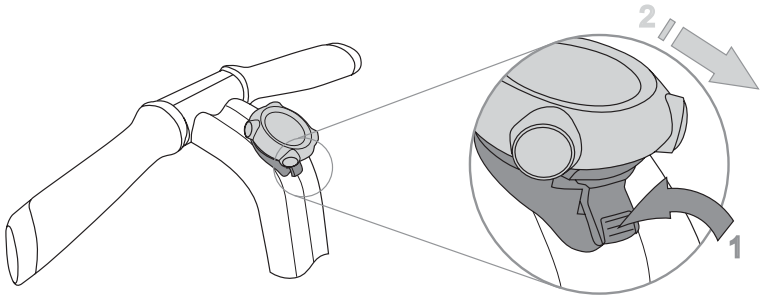

Figure 46. Undocking the InfoKey Controller

Chapter 7:

Troubleshooting the Segway PT

This chapter describes:

- Troubleshooting techniques.
- Using InfoKey Controller icons to help diagnose an error or failure condition.

Troubleshooting Procedures

You can troubleshoot certain problems with your Segway PT before contacting an Authorized Segway Dealer or Distributor, or Segway Customer Care. This chapter provides lists of problems and recommended actions.



WARNING!

Always shut down your Segway PT and unplug the AC Power Cord before performing any maintenance or installing any part or accessory.

Refer to **Table 13** for a list of potential errors. This table directs you to the page in this chapter where you can find more information on resolving the problem.

Table 13. Segway PT Troubleshooting Procedures

Problem:	See:
The Segway PT will not power on.	page 122
The Segway PT will not enter Balance Mode.	page 123
The LeanSteer Frame slips or is off-center.	page 124
The Tire/Wheel Assembly is loose and wobbles.	page 125
The Segway PT pulls to one side when riding.	page 126
A Tire is flat or will not maintain inflation pressure.	page 127
A Safety Shutdown occurs when you are entering or leaving a store, library, or other building.	page 127
The Segway PT will not power down.	page 128

If you are unable to solve the problem, look through the section showing the InfoKey Controller icons that display during error or failure conditions in **“Diagnosing Errors with InfoKey Controller Icons” on page 130**. That section shows the icons and recommended actions to take when you see certain icons.

If, after reviewing the troubleshooting procedures and the InfoKey Controller icons, you are still unable to resolve the problem, contact an Authorized Segway Dealer or Distributor, or Segway Customer Care. For a list of Authorized Dealers and Distributors, visit www.segway.com.

Segway PT Will Not Power On

Your Segway PT will not power on when you press the InfoKey Controller Power/Standby button. The procedure below will help you determine if you are standing in range for the InfoKey Controller to communicate with the Segway PT, whether the InfoKey Controller Battery needs replacement, whether your Segway PT needs to be “reset” by removing and reattaching the Batteries, or if you are experiencing a startup error.

You should review the following service procedures prior to troubleshooting this problem for important instructions and torque values.

- **“Removing the Batteries” on page 100**
- **“Reattaching the Batteries” on page 102**
- **“Replacing the InfoKey Controller Battery” on page 110**

Recommended Action:

1. Make sure your Segway PT's Batteries are charged.
2. Make sure you are standing with the InfoKey Controller no further than 15 ft. (5m) from your Segway PT.
3. Tap the InfoKey Controller Power/Standby button and verify that the Link Signal icon appears in the InfoKey display.
4. For more information, see **“InfoKey Controller” on page 19**.
5. If no Link Signal icon is displayed or the display is blank (no information displayed), remove and reseal the InfoKey Battery.
6. Tap the InfoKey Controller Power/Standby button. If the InfoKey display is blank, replace the InfoKey Controller Battery.
7. If the Warning icon appears (see **“InfoKey Controller” on page 19**) in the InfoKey Display when attempting to power on, see **“Startup Error Conditions” on page 130**.
8. If your Segway PT will still not power on, remove both Batteries and then reattach them.

Segway PT Will Not Enter Balance Mode

Your Segway PT will not enter Balance Mode.

Recommended Action:

Ensure that you have properly followed all instructions in “**Understanding Balance Mode**” and “**Riding Your Segway PT**” in the Getting Started Manual.

1. Confirm power has been turned on.
2. Confirm the LeanSteer Frame/Handlebar Assembly is centered and the Powerbase is level. (If you are positioned across a gentle slope, the LeanSteer Frame/Handlebar Assembly must be vertical side-to-side).
3. Confirm there is no weight on the Mats.
4. Check that the center Balance Indicator light is green and all four other Balance Indicator lights are not illuminated.
5. Tap the Mat with your foot without stepping on, then remove your foot. Confirm that all five Balance Indicator lights are pulsing green, and a smiling face icon shows in the InfoKey Controller display.
6. If the Segway PT still will not enter Balance Mode, identify the error icon on the InfoKey Controller, and attempt to clear the fault following the recommended actions in “**Startup Error Conditions**” on page 130.

The LeanSteer Frame Slips or is Off-Center

When you move the LeanSteer Frame, it slips on the Pivot Base Assembly, or the LeanSteer Frame is off-center and will not return to center.

You should review the following service procedures prior to troubleshooting this problem for important instructions and torque values.

- **“Removing the LeanSteer Frame” on page 93**
- **“Attaching the LeanSteer Frame” on page 96**

Recommended Action:

1. Loosen the LeanSteer Frame fastener with a 5mm hex wrench.
2. Align the LeanSteer Frame and visually check that the Handlebar is straight and centered. If it is not straight and centered, adjust the LeanSteer Frame to straighten and center it.
3. Tighten the LeanSteer Frame fastener to the correct torque value.
4. If the LeanSteer Frame still slips or falls off-center, loosen the LeanSteer Frame fastener and remove the LeanSteer Frame from the Pivot Base Assembly and ensure that the Pivot Base Assembly is clean and free of debris.
5. Remove the LeanSteer Frame fastener and Wedge Clamps and inspect them to make sure there is no slippery substance, and that the Wedge Clamps are not substantially worn and smooth.
6. If the Wedge Clamps are worn, replace them. If the Wedge Clamps or Pivot Base Assembly are not clean, thoroughly clean with isopropyl alcohol and ensure that all substance is removed prior to reinstalling the Wedge Clamps and LeanSteer Frame.
7. Attach the LeanSteer Frame to the Pivot Base Assembly.

Tire/Wheel Assembly is Loose and Wobbles

The Tire/Wheel assembly is not secure. It appears to be loose and wobbles.

You should review the following service procedures prior to troubleshooting this problem for important instructions and torque values.

- **“Removing the Tire/Wheel Assembly” on page 106**
- **“Installing the Tire/Wheel Assembly” on page 107**

Recommended Action:

1. Remove the Wheel Cap by pressing down on the outside edge, and lifting the opposite outside edge with your fingers or a plastic wedge.
2. Tighten the Wheel Nuts.
3. If the Tire/Wheel Assembly is still loose or wobbles, remove, clean, and reseal the Tire/Wheel Assembly and the flange on which the Tire/Wheel Assembly mounts.

Segway PT Pulls To One Side When Riding

Your Segway PT pulls to one side when you are riding.

You should review the following service procedure prior to troubleshooting this problem for important instructions: **“Checking Tire Inflation Pressure” on page 104.**

Recommended Action:

1. Check to make sure tire inflation pressure is equal, and set to recommended specifications in both Tires. See **“Tire Inflation Pressure” on page 5.**
2. If either Tire is not set at the proper tire inflation pressure, inflate the Tire or Tires until both are at equal and correct pressure.
3. Distribute your weight evenly on both feet. If you put more weight on one foot, the Segway PT will pull in that direction.

Tire is Flat or Will Not Hold Air

One of the Tires on your Segway PT is flat or will not hold air.

You should review the following service procedure prior to troubleshooting this problem for important instructions: “**Checking Tire Inflation Pressure**” on page 104.

Recommended Action:

1. Check for Tire damage. If the Tire is damaged, contact an Authorized Segway Dealer or Distributor to order a replacement Tire/Wheel Assembly.
2. If there is not visible Tire damage, check to make sure the Tire valve stem core is tight. Tighten the valve stem if necessary.
3. Inflate the Tire and check for leaks. If the Tire goes flat or will not maintain inflation pressure, contact an Authorized Segway Dealer or Distributor to order a replacement Tire/Wheel Assembly.

Safety Shutdown At Building Entrance

Theft detection systems, such as the type used in some libraries and retail stores can interfere with the Segway PT’s ability to balance and/or cause the Segway PT to perform a Safety Shutdown. Do not ride within 5 feet (1.5 meters) of any theft detection system. These systems may not always be visible.

Recommended Action:

1. Step off at least 5 feet (1.5 meters) away from theft detection systems and walk through the theft detection system in Standby Mode or with the Segway PT powered off.
2. Once you are at least 5 feet (1.5 meters) away from the theft detection system, return to Balance Mode and step on.

The Segway PT Will Not Power Down

Your Segway PT will not power down when you press and hold the Power/Standby button on the InfoKey Controller.

You should review the following service procedure prior to troubleshooting this problem for important instructions

- **“Removing/Installing the Mats” on page 109**
- **“Replacing the InfoKey Controller Battery” on page 110**

Recommended Action:

1. Check that your Mats are not sticking to the Powerbase.
2. If a Mat is sticking, lift the Mat to release it, being careful not to move your Segway PT forward or backward or move the LeanSteer Frame.
3. Press and hold the Power/Standby button on the InfoKey Controller for two seconds to confirm the problem is resolved.
4. If your Segway PT still will not power down, check that your InfoKey Controller Battery is not fully depleted and that the InfoKey Controller is not damaged. If necessary replace or reseal the InfoKey Controller Battery.

5. If reseating the InfoKey Controller Battery did not resolve the problem, and you do not have a replacement InfoKey Controller Battery:

Switch your Segway PT to Standby Mode by walking beside it while holding the Handlebar until you hear the Stick Shake Warning and feel the Segway PT switch out of Balance Mode, into Standby Mode.

Leave your Segway PT in a secure location for 15 minutes until it automatically powers down.

Install a new InfoKey Controller Battery.

6. Reinstall the Mat after your Segway PT is powered down.
7. Tap the Power/Standby button on the InfoKey Controller to power on your Segway PT, then press and hold Power/Standby button for two seconds to confirm the problem is resolved.

Diagnosing Errors with InfoKey Controller Icons

InfoKey Controller icons assist you in diagnosing certain errors. Match the icon shown in your InfoKey Controller display to those in the tables in this section to identify and attempt to correct the fault.

Startup Error Conditions



If you attempt to power on the Segway PT and an error condition occurs that prevents the Segway PT from powering on and entering Standby Mode, the icons shown in **Table 14** will appear on the InfoKey Controller.

To clear these conditions, follow the instructions in the Recommended Action column in **Table 14**.

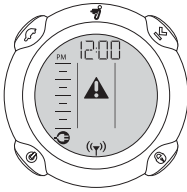
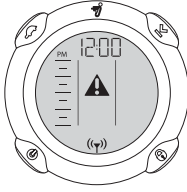

Do not step onto the Segway PT Mats until you have cleared all error conditions and have confirmed the Segway PT is in Balance Mode.

Table 14. Icons for Startup Errors

Display Icon	Description	Recommended Action
	<p>The Segway PT is plugged in.</p>	<p>Unplug the Power Cord. If the Segway PT has powered off, power on again.</p>
	<p>The charge in the Segway PT Batteries is too low to allow safe operation of the Segway PT.</p>	<p>Charge the Batteries, and then attempt to power on.</p>
	<p>A Rider Detect sensor is on at startup. (The corresponding icon in the display will blink).</p>	<p>Make sure your foot is not on the Mat when powering on your Segway PT.</p> <p>Check the Mat to ensure it is clear of foreign objects and not sticking to the Powerbase. If necessary, remove and inspect, then reinstall the Mats (see “Removing/Installing the Mats” on page 109).</p>

Balance Mode Error Conditions

If you unsuccessfully attempt to enter Balance Mode and step onto the Mat, the icon shown in **Table 15** will appear on the InfoKey Controller.

To clear this condition, follow the instructions in the Recommended Action column of **Table 15**.

Table 15. Icons for Errors Entering Balance Mode

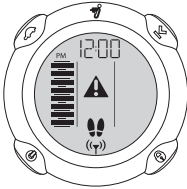
Display Icon	Description	Recommended Action
	<p>Powerbase is not level, or LeanSteer Frame is tilted when attempting to enter Balance Mode. This icon will display when you place your foot on the Mat.</p>	<p>Remove your foot from the Mat. Level the Powerbase and center the LeanSteer Frame until the center Balance Indicator light is green and no other Balance Indicator lights are illuminated.</p>

Reduced Performance Levels

When the Segway PT is operating at reduced performance levels due to an error condition, the icon shown in **Table 16** will appear on the InfoKey Controller. (See “**Speed Limiter**” on page 48 for a list of the conditions that cause reduced performance.)

To clear this condition, follow the instructions in the Recommended Action column of **Table 16**.

Table 16. Icons for Reduced Performance Level

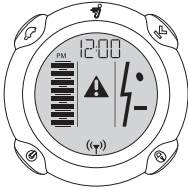
Display Icon	Description	Recommended Action
 The image shows a circular InfoKey Controller display. At the top, it displays 'PM 12:00'. Below the time is a battery level indicator with five bars. In the center, there is a warning icon consisting of a triangle with a lightning bolt and a minus sign. At the bottom, there is a small icon of a person riding a Segway PT.	<p>The Segway PT is operating at reduced performance levels, with the speed limit lowered, due to a temporary condition.</p>	<p>The Segway PT's Speed Limiter is an alert that you are moving too fast. When the Speed Limiter pushes the Handlebar back, stop leaning forward and slow down. Always leave a gap between yourself and the Handlebar. Once you slow to a speed that the Segway PT determines is safe, it will resume normal operation and riding position.</p>

Critical Faults While Riding

During normal riding, if the Segway PT detects a fault in any of its redundant subsystems, the icon shown in **Table 17** will appear on the InfoKey Controller.

When such a fault is detected, the Segway PT performs a Safety Shutdown. When a Safety Shutdown occurs, the Segway PT automatically reduces its speed, gives the Stick Shake Warning (shakes the Handlebar and makes a growling sound), flashes the Console lights, and the InfoKey displays a Safety Shutdown icon. As the Segway PT slows, it emits an audio alert.

Follow the instructions in the Recommended Action column of **Table 17**.

Table 17. Icon for Critical Faults in Redundant Subsystems

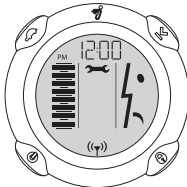
Display Icon	Description	Recommended Action
	The system has detected a critical error in its redundant subsystems and performs a Safety Shutdown.	The rider has approximately 10 seconds from the start of a Safety Shutdown to come to a controlled stop and step off. After 10 seconds, the Segway PT will immediately shut down when the Wheels reach zero speed.

Pitch or Roll Angle Exceeded

If the Segway PT shuts down because a forward/backward (pitch), or side (roll) tilt limit was exceeded, or no Rider Detect sensors were depressed while the Segway PT was moving at speed, the icon shown in **Table 18** will appear on the InfoKey Controller.

The Segway PT is programmed to shut down in these situations because the rider is not in control of the Segway PT.

To clear this condition, follow the instructions in the Recommended Action column of **Table 18**.

Table 18. Icons for Tilt Limits Exceeded

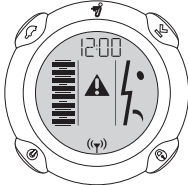
Display Icon	Description	Recommended Action
	The Segway PT shut down because a forward/backward (pitch), or side tilt limit was exceeded, or no Rider Detect sensors were depressed while the Segway PT was moving at speed.	Check the Segway PT for damage. If there is no damage, turn on power by tapping the Power/Standby button on the InfoKey Controller.

System Faults

If the Segway PT detects a hardware fault, the icons shown in **Table 19** will appear on the InfoKey Controller.

The Segway PT cannot be used until the fault is cleared. To attempt clear system faults, follow the instructions in the Recommended Action column of **Table 19**.

Table 19. Icons for System Faults

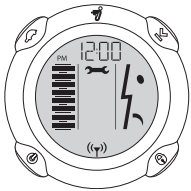
Display Icon	Description	Recommended Action
	<p>There is a fault in the Powerbase or Batteries.</p>	<ol style="list-style-type: none"> 1. Power on the Segway PT. 2. If the same icon appears, confirm that both Li-ion Batteries are installed correctly. 3. If the same icon appears remove and reseal both Batteries (see “Removing the Batteries” on page 100 and “Reattaching the Batteries” on page 102). 4. If the same icon appears, plug in your Segway PT and verify that both Battery Charge Indicator lights are green. Plug in and charge the Segway PT overnight.

Appendix A:

Contact and Legal Information

Report All Incidents

If you or any other user of your Segway PT is involved in an accident, or if your Segway PT performs in a way that you do not intend or in a way that it is not supposed to, contact Segway Customer Care by telephone at 866.4SEGWAY (866.473.4929), or by email at technicalsupport@segway.com.

How to Reach Us

Call Segway Customer Care (English-language only) at 866.473.4929.

Email Segway Customer Care (English-language only) at technicalsupport@segway.com.

An Authorized Segway Dealer or Distributor can answer questions about your Segway PT via the web, email, or phone. For a list of Dealers and Distributors, visit www.segway.com.

California Warning

This product contains chemicals, including lead, known to the State of California to cause cancer, birth defects or other reproductive harm.

Obey All Laws and Regulations

Many governmental authorities regulate use of Segway PTs on public roads and sidewalks. In addition to other requirements, these laws and regulations may prescribe minimum ages for Segway PT users and may set speed limits and mandate protective gear for riders. Some governmental authorities prohibit use of Segway PTs on public roads and sidewalks. You should consult local authorities to become familiar with applicable laws and regulations. (In the USA, many of these laws use the term “Electric Personal Assistive Mobility Device” or “Personal Motorized Mobility Device,” which are specifically defined to include Segway PTs.)

Limited Warranty

(United States Only)

Segway provides with each Segway PT a “Segway® Personal Transporter Limited Warranty.” This is the only warranty applicable to the Segway PT. Consult the “Segway® Personal Transporter Limited Warranty” delivered with your Segway PT for the specific terms of limited warranty coverage.

Radio Frequency Interference

United States FCC Part 15 Class B Radio Frequency Interference (RFI) Statement

The Segway PT has been tested and found to comply with the limits for Class B digital devices pursuant to Part 15 of the FCC rules. These limits are designed to provide reasonable protection against harmful interference in a residential environment. The Segway PT generates, uses, and can radiate radio frequency energy, and, if not installed and used in accordance with the User Materials may cause harmful interference to radio communications.

However, there is no guarantee that interference will not occur in a particular installation. If the Segway PT does cause harmful interference to radio or television reception, which can be determined by turning the Segway PT off and on, the user is encouraged to try and correct the interference by one or more of the following measures:

- Reorient or relocate the receiving antenna.
- Increase the distance between the Segway PT and the receiver.
- Connect the Segway PT into an outlet on a circuit different from that to which the receiver is connected.
- Consult the dealer or an experienced radio/TV technician for help.
- Operation is subject to the following two conditions
 - This device may not cause harmful interference
 - This device must accept any interference received, including interference that may cause undesired operation

This product complies with FCC radiation exposure limits set forth for an uncontrolled environment.

Modifications: Modifications not expressly approved by Segway may void the user's authority to operate this device under FCC regulations and must not be made.

FCC ID: T2Z2420-01

IC: 6396A-242001

Canadian ICES-003

The Segway PT is a Class B digital apparatus that complies with Canadian ICES-003

European Directives

The Segway PT complies with the requirements of the European Directives 89/336/EEC, Directive of Electromagnetic Compatibility; 73/23/EEC, Low Voltage Directive; and 98/37/EC, Machinery Directive.

Other Standards

The Segway PT also complies under the applicable sections of the following:

IEC 60950-00; CAN/CSA C22.2 No. 60950-01-03; UL 60950; UL Standard for Safety for Motor-Operated Appliances, UL 73; Motor-Operated Appliances (Household and Commercial), CAN/CSA-C22.2 No. 68-92; Degrees of Protection Provided by Enclosures (IP Code) IEC 60529; Household and Similar Electrical Appliances Safety-General Requirements, IEC 60335-1; Safety of Machinery - Basic Concepts, General Principles for Design - Part 1: Basic Terminology, ISO 121001-1; Safety of Machinery - Basic Concepts, General Principles for design -Part 2:Technical Principles

Patent Information

The Segway PT is covered by US and foreign patents, including one or more of the following:

US Patent numbers (issued): 5,701,965; 5,791,425; 5,794,730; 5,971,091; 5,975,225; 6,223,104; 6,288,505; 6,302,230; 6,332,103; 6,357,544; 6,367,817; 6,405,816; 6,408,240; 6,415,879; 6,435,535; 6,443,250; 6,538,411; 6,543,564; 6,553,271; 6,561,294; 6,571,892; 6,575,539; 6,581,714; 6,598,941; 6,651,763; 6,651,766; 6,715,845; 6,779,621; 6,789,640; 6,796,396; 6,799,649; 6,815,929; 6,827,163; D489,027; D489,029; D489,300; D493,127; D493,128; D493,129; D493,392; D493,749; 6,965,206; 6,929,080; 7,017,686; 6,874,591; 6,920,947; 6,866,107; 7,023,330; 6,868,931; 7,000,933.

US Patent Pending (published application serial numbers): 20040011573; 20040050611; 20040055795; 20040055796; 20040069543; 20040183272; 20050017733; 20050121866; 20050236215.

Foreign Patent numbers (issued): AU: 705704; 726250; 726253; 727183; 728453; 729781; 738013. CA: 2211738. KR: 346992; 351082; 363809. MX: 205144. NZ: 282114; 330431. RU: 2153868. TW: 129673; 130073; 154350; 157146; 159151; 171,217.

Foreign Patent Pending (published application serial number): AT: 95911624.5. AU: 62669/99; 21703/00; 37202/00; 37430/00; 37450/00; 33980/00; 54557/00; 53137/00; 80362/00. BE: 95911624.5. CA: 2,211,738; 2,346,442; 2,337,130; 2,363,737; 2,367,501; 2,375,313; 2,366,076; 2,373,275; 2,375,645; 2,382,360; 2,393,418; 2,401,488; 2,431,070. CH: 95911624.5. CN: 95197546.3; 00812269.5; 95197546.3. DE: 95911624.5; 00916035.9. DK: 95911624.5. ES: 95911624.5. EP: 1123235; 1159686; 1161214; 1161215; 1161216; 1180996; 1181187; 1183163; 1208032; 1237779; 1259415; 1298041; 1324911. FI: 973197. FR: 95911624.5; 00916035.9. GB: 95911624.5; 00916035.9. GR: 95911624.5. HK: 02101085.2; 02106106.6; 02106105.7; 03105015.7; 02106266.2; 02108322.0. ID: W00200102875; W00200102136; W00200102823; W00200200009; W00200200024; W00200200451; W00200201309. IE: 95911624.5; IL: 155,390. IN: IN/PCT/02/00280/CHE. IT: 95911624.5. JP: 8-523486; 2000-577062; 2001-508659; 2000-602941; 2000-604799; 2000-621191; 2000-604801; 2001-501161; 2001-501493; 2001-519543; 2001-543388; 2001-563370; 2003-35305. KR: 10-2001-7016896; 10-2001-7011189; 10-2001-7015260; 10-2001-7015490; 10-2001-7015564; 10-2002-7002673; 10-2002-7007338. MC: 95911624.5. MX: 2001/004018; PA/a/2001/012685; PA/a/2001/008933; PA/a/2001/009342; PA/a/2001/012232; PA/a/2001/009374; PA/a/2000/12498; PA/a/2001/012557; PA/a/2002/002217; PA/a/2002/005801; 000162. MY: PI20000540; PI20001210; PI200010118; PI20001458; PI20002479; PI20002502; PI 200014753. NL: 95911624.5. NO: P973,153; 20011809. NZ: 513868; 517412; 525279. RU: 2000114547; 2002108569. SE: 95911624.5. SG: 200201245-8; 200203390-0. TW: 88117468; 89,106,673; 89,110,752. WO: 00/23315; 00/52588; 00/54719; 00/54720; 00/54721; 00/61426; 00/73101; 00/74623; 00/75001; 01/02920; 01/064502; /01/15962; 01/42077; 02/030730; 02/068219; 2003/103559; 03/105967; 2003/106250; 2004/007233; 2004/007264; 2004/075804; 2004/078603; 2005/009828.

Additional US and foreign patent applications are pending.

Segway Inc. manufactures and sells Segway PTs under a license from DEKA Products Limited Partnership.

Index

A

- Accessories 91
- Attaching
 - the Handlebar 99
 - the LeanSteer Frame 96

B

- Balance Indicator lights 37
- Balance Sensor Assembly 45
- Batteries 46, 61
 - reattaching 102
 - removing 100
 - replacing 77
 - shipping 78
 - specifications 63
 - transporting 78

Battery

- InfoKey Controller 110
- Battery Charge Indicator
 - lights 40, 69
- Battery charge level display 71
- Battery safety 61
- Beginner button 21
- Beginner icon 22

C

- Carrying cargo 8
- Center of gravity 14
- Charge Port 65
- Charging Batteries 64
- Charging failures 70
- Checking the Tire/Wheel
 - Assembly 84

- Checking Tire inflation
 - pressure 104
- Cleaning your Segway PT 86
- Console 35
- Console Trim 40
- Controller Boards 43
- Conventions xii
- Critical error 134
- Critical faults when riding 134

D

- Diagnosing errors 130
- Dynamic stabilization 13

E

- Empty Battery condition 59
- Errors
 - attempting to Enter Balance Mode and Step On 132
 - critical 134

F

- Face icons 22
- Fenders 34
 - installing 108
 - removing 108
- Foreign patent numbers 141

H

- Handlebar 16
 - attaching 99
 - cargo 9
 - removing 98

I

- i2 description 4
- Indicator lights
 - Balance 37
 - Battery Charge 40, 69
- InfoKey Controller
 - battery replacement 110
 - buttons 19
 - display area 20
 - Dock Adapter installation 115
 - Dock installation 113
 - error conditions 130
 - serial number 3
- Information Display 22
- Information Display button 21
- Installing
 - Fenders 108
 - InfoKey Controller Dock 113
 - InfoKey Controller Dock Adapter 115
 - LeanSteer Frame 96
 - Mats 109
 - Tire/Wheel assembly 107

L

- Laws and regulations 138
- LeanSteer Frame 16
 - attaching 96
- LeanSteer Frame/Handlebar Assembly 16
- Lifting Your Segway PT 82

M

- Maintaining Tires and Wheels 84
- Mats 16, 35
 - installing 109
 - removing 109
- Maximum handlebar cargo weight 9
- Maximum speed 5

- Maximum weight limit 5
- Minimum weight limit 9
- Model descriptions 4
- Motors 44

O

- Operating limits 8
- Operating temperature
 - batteries 63

P

- Parts diagram 90
- Patent and licensing information 141
- Performance and temperature 74
- Pitch or roll angle exceeded 135
- Power requirements 5
- Power/Standby button 21
- Powerbase height 6

R

- Range on a full charge 5
- Reattaching the Batteries 102
- Recalibrating the Battery charge level display 72
- Reduced performance levels 133
- Redundant subsystems 16
- Regenerative braking 70
- Removing
 - Batteries 100
 - Fenders 108
 - Handlebar 98
 - LeanSteer Frame 93
 - Mats 109
 - Tire/Wheel assembly 106
- Replacing parts 91
- Replacing the InfoKey Controller Battery 110
- Reseating the InfoKey Controller Battery 110
- Rider Detect Sensors 41

S

- Safety alerts 47
- Safety Shutdown 43, 55, 134
- Security button 21
- Security icon 22
- Segway PT
 - components 16
 - how it works 14
 - serial number 2
 - specifications 5
 - subsystems 16
- Service procedures 92
- Servicing your Segway PT 89
- Shipping Li-ion Batteries 79
- Specifications 5
- Speed Limiter 48
 - description 48
- Startup error conditions
 - inadequate battery charge 131
 - plugged in 131
 - Rider Detect Sensor depressed 131
- Stick Shake Warning 51
 - description 51
 - rider off 54
 - rider on 52
- Storing your Segway PT 88
- Structural weight limits 10
- System faults 136

T

- Temperature
 - effect on performance 74
- Tire inflation pressure 5
 - checking 84, 104

- Tire/Wheel Assembly 16
 - installing 107
 - removing 106
- Torque specifications 91
- Traction 87
- Transporting and shipping Batteries 78
- Transporting your Segway PT 78
- Troubleshooting 119
 - flat tire 126
 - LeanSteer Frame 124
 - procedures 119
 - pulls to one side when riding 126
 - Safety Shutdown occurs 126
 - will not enter balance mode 122
 - will not power off 126
 - will not power on 122
- Turning radius 5

U

- US patent numbers 141

W

- Warranty 138
- Weight limits 8
- Wrench icon 22

X

- x2 description 4

